

## ENGINE TOOL PARTS LIST

### ENGINE POLE HEDGE TRIMMER

2013-3-28

### Model TCH 22EPAP (TANAKA BRAND)

(E1)

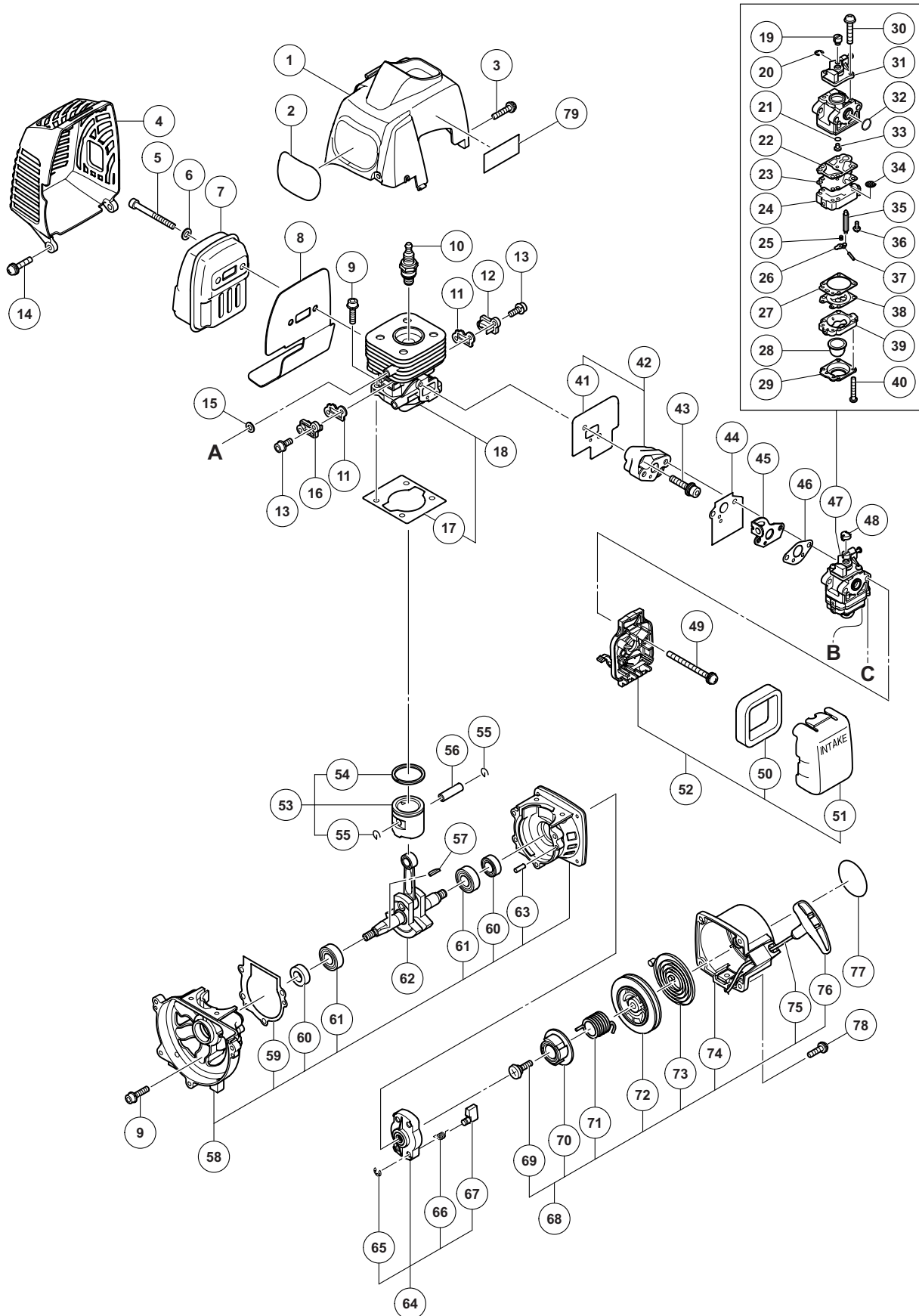

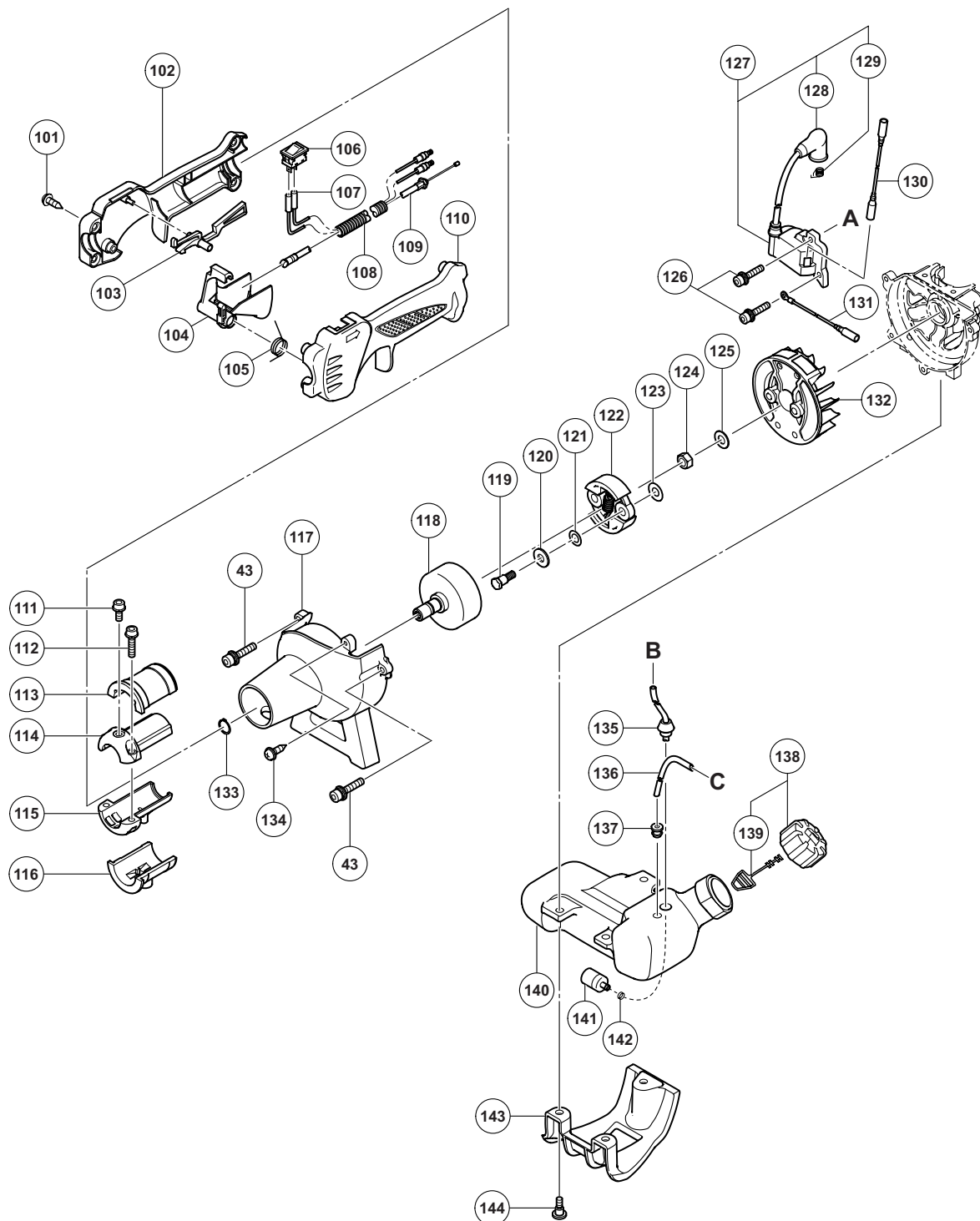

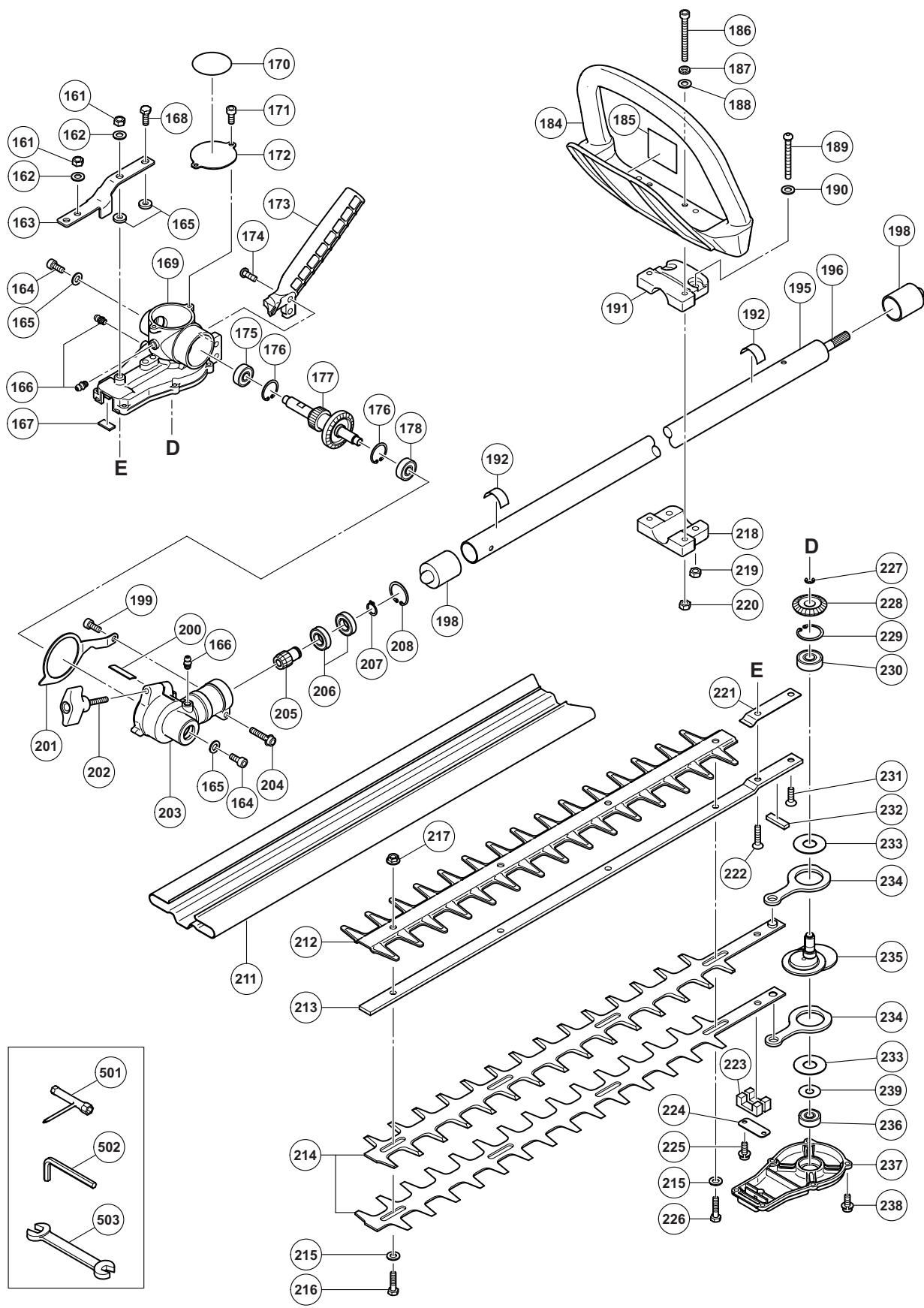

**PARTS**

TCH 22EPAP

ITEM NO.	CODE NO.	DESCRIPTION	NO. USED	REMARKS
1	669-7680	CYLINDER COVER	1	
2	669-7961	NAME PLATE (TCG)	1	
3	669-5376	SCREW 4 X 22/PS	2	
4	669-7692	MUFFLER PROTECTOR	1	
5	668-4638	HEX. HOLE BOLT M6 X 55	2	
6	668-4639	BOLT WASHER 6	2	
7		MUFFLER	1	
8	669-6553	HEAT PROTECTION PANEL	1	
9	669-5491	HEX. HOLE BOLT 5 X 20S	8	
10	668-4584	SPARK PLUG BMR7A	1	
11	669-6922	INTAKE COVER PACKING	2	
12	669-6535	INTAKE COVER (A)	1	
13	669-5507	HEX. HOLE BOLT 4 X 12WS	4	
14	669-5386	SCREW 5 X 16/PS	2	
15	668-4600	WASHER T1.6	2	
16	669-6536	INTAKE COVER (B)	1	
17	669-6920	CYLINDER PACKING	1	
18	669-7962	CYLINDER SET PN	1	INCLUD. 17
19	668-4697	SWIVEL	1	
20	668-4696	STOP RING	1	
21	668-4695	O-RING	1	
22	668-4692	PUMP GASKET	1	
23	668-4693	PUMP DIAPHRAGM	1	
24		PUMP BODY	1	
25	669-6323	METERING LEVER SPRING	1	
26	668-5217	CONTROL LEVER	1	
27	668-4691	DIAPHRAGM GASKET	1	
28	668-4689	PRIMING BODY	1	
29	668-4688	DIAPHRAGM COVER	1	
30	668-4698	THROTTLE SET SCREW	2	
31	668-4883	THROTTLE VALVE	1	
32	669-5670	O-RING P-15	1	
33		MAIN JET #32	1	
34	668-4700	INLET SCREEN	1	
35	668-5215	NEEDLE VALVE	1	
36	669-1305	HINGE PIN SET SCREW	1	
37	668-5219	HINGE PIN	1	
38	668-4690	METERING DIAPHRAGM	1	
39	668-4687	PRIMING PUMP COMP.	1	
40	668-4699	SET SCREW	4	
41	669-6933	INTAKE PACKING	1	
42	669-9016	CARBURETOR INSULATOR SET PN	1	INCLUD. 41
43	669-8844	SEAL LOCK HEX. SOCKET BOLT (W/WASHERS) M5	5	
44	668-4616	CARBURETOR PACKING	1	
45	668-4629	THROTTLE WIRE FIXING PLATE	1	
46	668-4615	CARBURETOR GASKET	1	
47	669-8960	CARBURETOR ASS'Y	1	INCLUD. 19-40
48	669-1337	SWIVEL CAP	1	
49	669-5431	PLUS SCREW 5 X 60WS	2	
50	669-0347	CLEANER ELEMENT	1	

**PARTS**

TCH 22EPAP

ITEM NO.	CODE NO.	DESCRIPTION	NO. USED	REMARKS
51	669-0139	AIR CLEANER CAP	1	
52	669-8961	AIR FILTER ASS'Y	1	INCLUD. 50, 51
53	669-7682	PISTON SET	1	INCLUD. 54, 55
54	668-6118	PISTON RING	1	
55	668-4590	CIR CLIP	2	
56	669-6944	PISTON PIN	1	
57	668-4899	WOODRUFF KEY 3 X 13 X 4.5	1	
58	669-7686	CRANK CASE ASS'Y	1	INCLUD. 59-61, 63
59	669-6925	CRANK CASE PACKING	1	
60	668-4607	OIL SEAL TB 12227	2	
61	668-4608	BALL BEARING 6001 C3	2	
62	669-9017	CRANK SHAFT COMP.	1	
63	669-5521	KNOCK PIN 4 X 12	2	
64	668-4681	STARTER PULLEY ASS'Y	1	INCLUD. 65-67
65	668-4683	STOP RING E-5	2	
66	668-4684	STARTER PAWL SPRING	2	
67	668-4685	STARTER PAWL	2	
68	668-4672	RECOIL STARTER BODY ASS'Y	1	INCLUD. 69-76
69	668-4679	SET SCREW	1	
70	668-4678	CAM PLATE	1	
71	668-4677	DAMPER SPRING	1	
72	668-4676	STARTER ROPE REEL	1	
73	669-7591	RECOIL SPRING	1	
74	668-4673	RECOIL STARTER BODY COMP.	1	
75	669-7590	STARTER ROPE 3.5 X 860	1	
76	668-4680	STARTER HANDLE	1	
77		NAME PLATE (TCH 22EPAP)	1	
78	669-5374	SCREW 4 X 16/PS	2	
79		CAUTION PLATE (USA)	1	
101	669-7190	TAPPING SCREW D4	4	
102	669-6487	HANDLE (B)	1	
103	669-6490	LOCK LEVER	1	
104	669-6488	LEVER	1	
105	669-8819	SPRING (A)	1	
106	668-5239	STOP SWITCH	1	
107	669-8820	STOP SWITCH CORD	2	
108	669-8822	PROTECTION TUBE	1	
109	669-8821	THROTTLE WIRE	1	
110	669-6486	HANDLE (A)	1	
111	668-4667	HEX. HOLE BOLT M5 X 12/S	1	
112	668-4709	HEX. HOLE BOLT M5 X 25/S	2	
113	668-4666	ANTI-VIBE RUBBER (A)	1	
114	669-8643	PIPE HOLDER (A)	1	
115	669-8644	PIPE HOLDER (B)	1	
116	668-4665	ANTI-VIBE RUBBER (B)	1	
117	669-7841	FAN CASE COMP.	1	
118	668-4663	CLUTCH DRUM COMP.	1	
119	668-9627	STEP BOLT	2	
120	668-4648	BENT WASHER 8	2	
121	668-9528	CLUTCH PLATE (A)	2	

**PARTS**

TCH 22EPAP

ITEM NO.	CODE NO.	DESCRIPTION	NO. USED	REMARKS
122	669-7655	CLUTCH SET	1	
123	669-7619	CLUTCH WASHER B	2	
124	668-4612	HEX. NUT M8	1	
125	668-4611	BOLT WASHER M8	1	
126	669-5508	HEX. HOLE BOLT 4 X 18WS	2	
127		IGNITION COIL ASS'Y	1	INCLUD. 128, 129
128		PLUG CAP	1	
129		METAL FITTING OF PLUG CAP	1	
130	669-8992	CORD	1	
131	669-7690	CORD	1	
132		MAGNETO ROTOR	1	
133	668-4664	STOP RING C-12 OUTER	1	
134	668-4636	TAPPING SCREW D4.5 X 16	1	
135	669-8970	SHIELD TUBE SET	1	
136	669-2358	FUEL PIPE 3 X 5 X 95	1	
137	669-7846	RETURN GROMMET	1	
138	668-4622	TANK CAP ASS'Y	1	INCLUD. 139
139	668-4625	TANK CAP CHAIN	1	
140	669-6552	TANK	1	
141	668-4620	PUMP FILTER BODY COMP.	1	
142	668-4619	CLIP, 6.3 DIA.	1	
143	669-6556	STAND	1	
144	669-6557	FLANGE BOLT	3	
161	669-5175	LOCK NUT 6 UPS-P	2	
162	668-4639	BOLT WASHER 6	2	
163	669-0744	SUPPORT PLATE	1	
164	669-5078	HEX. HOLE BOLT 6 X 12	2	
165	668-4822	SPECIAL WASHER B	4	
166	668-8643	GREASE NIPPLE COMP.	3	
167	668-6659	GREASE STOP (B)	1	
168	669-5016	PLUS BOLT 6 X 14	1	
169	668-8834	GEAR CASE (B)	1	
170	669-4538	CAUTION MARK A TANAKA	1	
171	669-5035	HEX. HOLE BOLT 4 X 8	2	
172	668-9167	GEAR CASE COVER (A)	1	
173	668-8089	HANDLE	1	
174	669-5079	HEX. HOLE BUTTON SCREW 6 X 15	2	
175	608-DDM	BALL BEARING 608DDC2PS2L	1	
176	669-5293	RETAINING RING C-TYPE D22	2	
177	669-8957	GEAR SHAFT	1	
178	333-945	BALL BEARING 608VV	1	
184	668-8096	FRONT HANDLE	1	
185	669-4415	CAUTION MARK	1	
186	669-5056	HEX. HOLE BOLT 5 X 55	2	
187	668-4834	SPRING WASHER 5	2	
188	668-4918	WASHER M5 (BLACK)	2	
189	668-4714	HEX. HOLE BUTTON SCREW 6 X 25S	2	
190	669-5194	WASHER 6	2	
191	668-8103	BRACKET A	1	
192	668-4851	LEVEL MARK	2	

**PARTS**

TCH 22EPAP

<b>ITEM NO.</b>	<b>CODE NO.</b>	<b>DESCRIPTION</b>	<b>NO. USED</b>	<b>REMARKS</b>
195		DRIVE SHAFT PIPE 600L	1	
196	668-9439	DRIVE SHAFT 633L	1	
198	669-8515	CAP (A)	2	
199	669-5042	HEX. HOLE BOLT 5 X 10	1	
200	668-6669	GREASE STOP (D)	1	
201	668-8159	ANGLE LIMITER	1	
202	669-1200	HANDLE KNOB A COMP.	1	
203	668-8653	GEAR CASE A, 24 DIA.	1	
204	668-4709	HEX. HOLE BOLT M5 X 25/S	1	
205	669-8958	PINION	1	
206	669-8971	BALL BEARING 6901ZZC3	2	
207	669-5302	STOP RING S-12, OUTER	1	
208	668-4732	STOP RING C-24, INNER	1	
211	668-7301	CUTTER COVER	1	
212	668-7281	PROTECTION PLATE	1	
213	668-7125	CUTTER GUIDE 625.5 MM	1	
214	668-7079	CUTTER (A)	2	
215	668-7187	WASHER 7 BLACK	4	
216	668-7162	CUTTER FIXING BOLT B	3	
217	669-5170	FLANGE NUT 6	3	
218	668-8104	BRACKET B	1	
219	668-4835	HEX. NUT 6	2	
220	668-5075	NUT M5 (BLACK)	2	
221	668-8633	SPACER	1	
222	669-5075	HEX. HOLE FLUSH BOLT 6 X 25	1	
223	668-6647	GREASE STOP (A)	2	
224	668-6826	CAM ROD PLATE	1	
225	669-5484	HEX. HOLE BOLT 4 X 10S	2	
226	668-7158	FIXING BOLT A M6	1	
227	669-5310	RETAINING RING E-TYPE D6	1	
228	669-8959	GEAR 2	1	
229	669-5294	RETAINING RING C-TYPE D26	1	
230	669-5525	BALL BEARING #6000ZZ, 26 MM/OD	1	
231	669-5073	HEX. HOLE FLUSH SCREW 6 X 16	1	
232	668-6666	GREASE STOP (C)	1	
233	668-6611	CAM-ROD GUIDE PLATE	2	
234		CAM ROD (A)	2	
235	668-6790	CAM SHAFT COMP.	1	
236	669-8772	BALL BEARING 608ZZC3	1	
237	668-9172	GEAR CASE COVER B	1	
238	668-4595	HEX. SOCKET HD. BOLT (W/SP. WASHER) M4 X 12	6	
239		SPECIAL WASHER	1	

