

HITACHI

LIST NO. E449

ELECTRIC TOOL PARTS LIST

■ HAMMER

1998 · 10 · 20

Model H 60MB

(E1)

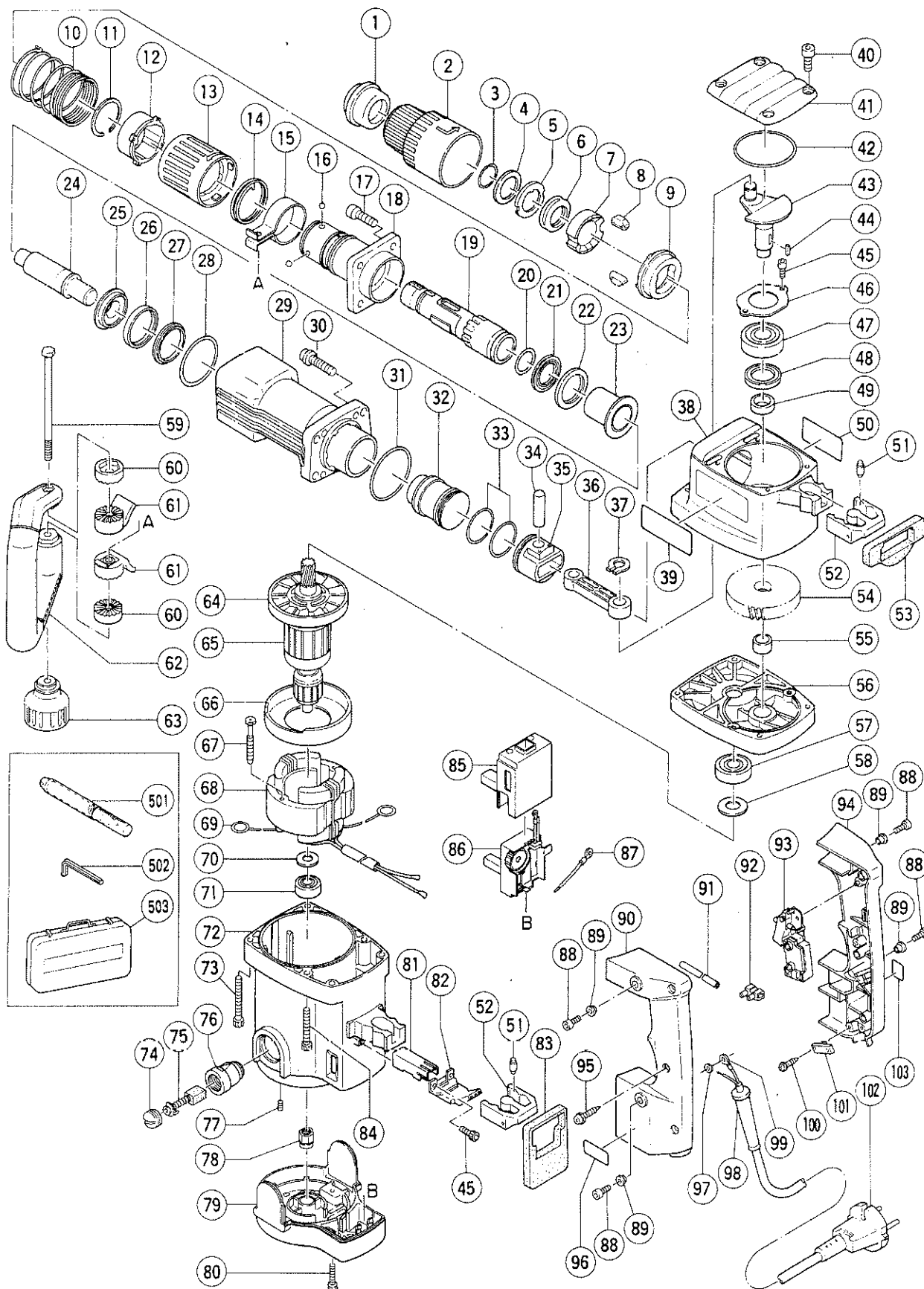

PARTS

H 60MB

ITEM No.	CODE NO.	DESCRIPTION	NO. USED	REMARKS
1	315-529	FRONT CAP	1	
2	315-506	GRIP (A)	1	
3	315-512	RING	1	
4	315-507	WASHER (D)	1	
5	315-508	WASHER (C)	1	
6	315-509	RETAINER DAMPER	1	
7	315-510	NEEDLE HOLDER (A)	1	
8	315-514	NEEDLE	2	
9	315-511	NEEDLE HOLDER (B)	1	
10	315-515	SPRING (A)	1	
11	317-088	RETAINING RING D42	1	
12	315-518	BALL HOLDER	1	
13	315-513	GRIP (B)	1	
14	315-516	SPRING (B)	1	
15	317-104	BAND	1	
16	959-150	STEEL BALL D6.35 (10 PCS.)	4	
17	985-479	SEAL LOCK HEX. SOCKET HD. BOLT M8X25	4	
18	317-089	FRONT COVER	1	
19	315-519	RETAINER SLEEVE	1	
20	872-470	O-RING (S-26)	1	
21	315-521	X-RING	1	
22	317-094	DAMPER (B)	1	
23	317-092	HAMMER HOLDER (B)	1	
24	317-090	SECOND HAMMER	1	
25	317-091	HAMMER HOLDER (A)	1	
26	317-093	DAMPER	1	
27	317-095	DAMPER WASHER	1	
28	317-119	O-RING (S-56)	1	
29	317-085	CYLINDER CASE	1	
30	990-083	HEX. SOCKET HD. BOLT (W/FLANGE) M8X35	4	
31	956-996	O-RING (1AS-60)	1	
32	301-510	STRIKER	1	
33	985-454	O-RING (A) (FPM810)	2	
34	301-509	PISTON PIN	1	
35	317-084	PISTON	1	
36	317-082	CONNECTING ROD	1	
37	939-543	RETAINING RING FOR D14 SHAFT (10 PCS.)	1	
38	317-083	CRANK CASE	1	
39		HITACHI LABEL	1	
40	990-079	SEAL LOCK HEX. SOCKET HD. BOLT M5X16	4	
41	317-079	CRANK COVER	1	
42	993-195	O-RING	1	
43	317-078	CRANK SHAFT	1	
44	940-533	FEATHER KEY 3X3X10	1	
45	984-509	SEAL LOCK HEX. SOCKET HD. BOLT M5X14	4	
46	985-443	BEARING COVER	1	
47	620-4DD	BALL BEARING 6204DDUCMPS2S	1	
48	995-403	OIL SEAL	1	
49	995-402	DISTANCE RING (C)	1	
50		NAME PLATE	1	
51	310-124	HANDLE DAMPER	8	

* : ALTERNATIVE PARTS

10 - 98

PARTS

H 60MB

ITEM No.	CODE NO.	DESCRIPTION	NO. USED	REMARKS
52	310-123	TRANSATORY UNIT	2	
53	317-101	HANDLE PACKING (A)	1	
54	317-080	FIRST GEAR	1	
55	985-442	NEEDLE BEARING (A) (BK1512)	1	
56	317-081	GEAR COVER ASS'Y	1	INCLUD.55
57	620-3DD	BALL BEARING 6203DDUCMAV2S	1	
58	992-841	BEARING WASHER	1	
59	317-107	BOLT M8	1	
60	317-106	HANDLE HOLDER (B)	2	
61	317-105	HANDLE HOLDER (A)	2	
62	317-103	SIDE HANDLE ASS'Y	1	INCLUD.15,59-61,63
63	317-108	GRIP	1	
64	996-370	FAN	1	
* 65	360-486U	ARMATURE ASS'Y 110V-115V	1	INCLUD.57,58,64,70,71
* 65	360-486E	ARMATURE ASS'Y 230V	1	INCLUD.64
* 65	360-486F	ARMATURE ASS'Y 240V	1	INCLUD.64
66	305-610	FAN GUIDE	1	
67	953-121	HEX. HD. TAPPING SCREW D5X50	2	
* 68	340-432C	STATOR ASS'Y 119V	1	INCLUD.69
* 68	340-432G	STATOR ASS'Y 115V	1	INCLUD.69
* 68	340-432E	STATOR ASS'Y 230V	1	INCLUD.69
* 68	340-432F	STATOR ASS'Y 240V	1	INCLUD.69
69	945-932	BRUSH TERMINAL	2	
70	944-954	BEARING WASHER	1	
71	620-1DD	BALL BEARING 6201DDUCMAV2S	1	
72	317-077	HOUSING ASS'Y	1	INCLUD 76,77
73	301-567	SEAL LOCK HEX. SOCKET HD. BOLT M6X55	4	
74	940-540	BRUSH CAP	2	
75	999-074	CARBON BRUSH (AUTO STOP TYPE) (1 PAIR)	2	
76	956-984	BRUSH HOLDER	2	
77	938-477	HEX. SOCKET SET SCREW M5X8	2	
78	317-087	MAGNET	1	
79	317-086	TAIL COVER	1	
80	317-245	SEAL LOCK HEX. SOCKET HD. BOLT M5X22	2	
81	317-099	SLEEVE	1	
82	980-754	INTERNAL WIRE HOLDER	1	
83	317-102	HANDLE PACKING (B)	1	
84	986-940	SEAL LOCK HEX. SOCKET HD. BOLT M6X45	2	
85	317-100	CASE (B)	1	
* 86	317-109	CONTROLLER CIRCUIT 110V	1	
* 86	317-112	CONTROLLER CIRCUIT 115V	1	
* 86	317-110	CONTROLLER CIRCUIT 230V-240V	1	
* 87	317-113	INTERNAL WIRE	1	EXCEPT USA
88	991-690	SEAL LOCK HEX. SOCKET HD. BOLT M5X12	4	
89	991-711	DISTANCE PIECE (B)	4	
90	317-097	HANDLE (B)	1	
* 91		VINYL TUBE(D7XT0.5X30)	2	FOR USA
92	938-307	PILLAR TERMINAL	1	
93	306-143	SWITCH (B) (1P SCREW TYPE) W/LOCK	1	
94	317-096	HANDLE (A)	1	
95	307-028	TAPPING SCREW (W/FLANGE) D4X25 (BLACK)	3	

PARTS

H 60MB

ITEM No.	CODE NO.	DESCRIPTION	NO. USED	REMARKS
96		SDS-MAX LABEL	1	
* 97	949-423	WASHER M4 (10 PCS.)	1	EXCEPT USA
* 98	953-327	CORD ARMOR D8.8	1	
* 98	938-051	CORD ARMOR D10.1	1	
* 99	992-810	TERMINAL	1	
* 99	980-063	TERMINAL	1	FOR GBR(110V),SAF,AUS
* 99	930-804	TERMINAL M4.0 (10 PCS.)	1	FOR USA
100	984-750	TAPPING SCREW (W/FLANGE) D4X16	2	
* 101	960-266	CORD CLIP	1	
* 101	981-987Z	CORD CLIP	1	FOR SUI
* 102	500-390Z	CORD	1	(CORD ARMOR D10.1)
* 102	500-446Z	CORD	1	(CORD ARMOR D10.1) FOR GBR (230V)
* 102	500-454Z	CORD	1	(CORD ARMOR D8.8) FOR GBR (110V),SAF
* 102	500-408Z	CORD	1	(CORD ARMOR D10.1) FOR AUS
* 102	500-391Z	CORD	1	(CORD ARMOR D10.1) FOR SUI
* 102	500-434Z	CORD	1	(CORD ARMOR D8.8) FOR USA
103		LABEL	1	

STANDARD ACCESSORIES

ITEM No.	CODE NO.	DESCRIPTION	NO. USED	REMARKS
501	313-471	BULL POINT (SDS MAX) 280L	1	
502	872-422	HEX. BAR WRENCH 6MM	1	
503	317-125	CASE (STEEL)	1	

OPTIONAL ACCESSORIES

ITEM No.	CODE NO.	DESCRIPTION	NO. USED	REMARKS
601	981-840	GREASE (A) FOR HAMMER.HAMMER DRILL (30G)	1	
602	308-471	GREASE FOR HAMMER.HAMMER DRILL (70G)	1	
* 603	980-927	GREASE FOR HAMMER.HAMMER DRILL (500G)	1	EXCEPT USA
604	313-472	BULL POINT (SDS MAX) 400L	1	
605	313-473	COLD CHISEL (SDS MAX) 280MM	1	
606	313-474	COLD CHISEL (SDS MAX) 400MM	1	
607	313-475	CUTTER (SDS MAX) W50X400L	1	
608	313-476	SCOOP (SDS MAX) 400L	1	
609	313-477	BUSHING TOOL (SDS MAX)	1	
610	313-478	RAMMER (SDS MAX) 150MM X 150MM	1	
611	313-479	SHANK (SDS MAX)FOR RAMMER,BUSHING TOOL	1	

* : ALTERNATIVE PARTS

Printed in Japan 10 - 98
(981020 N)