

ELECTRIC TOOL PARTS LIST

HAMMER
Model H 41MB

2010·9·2
(E1)

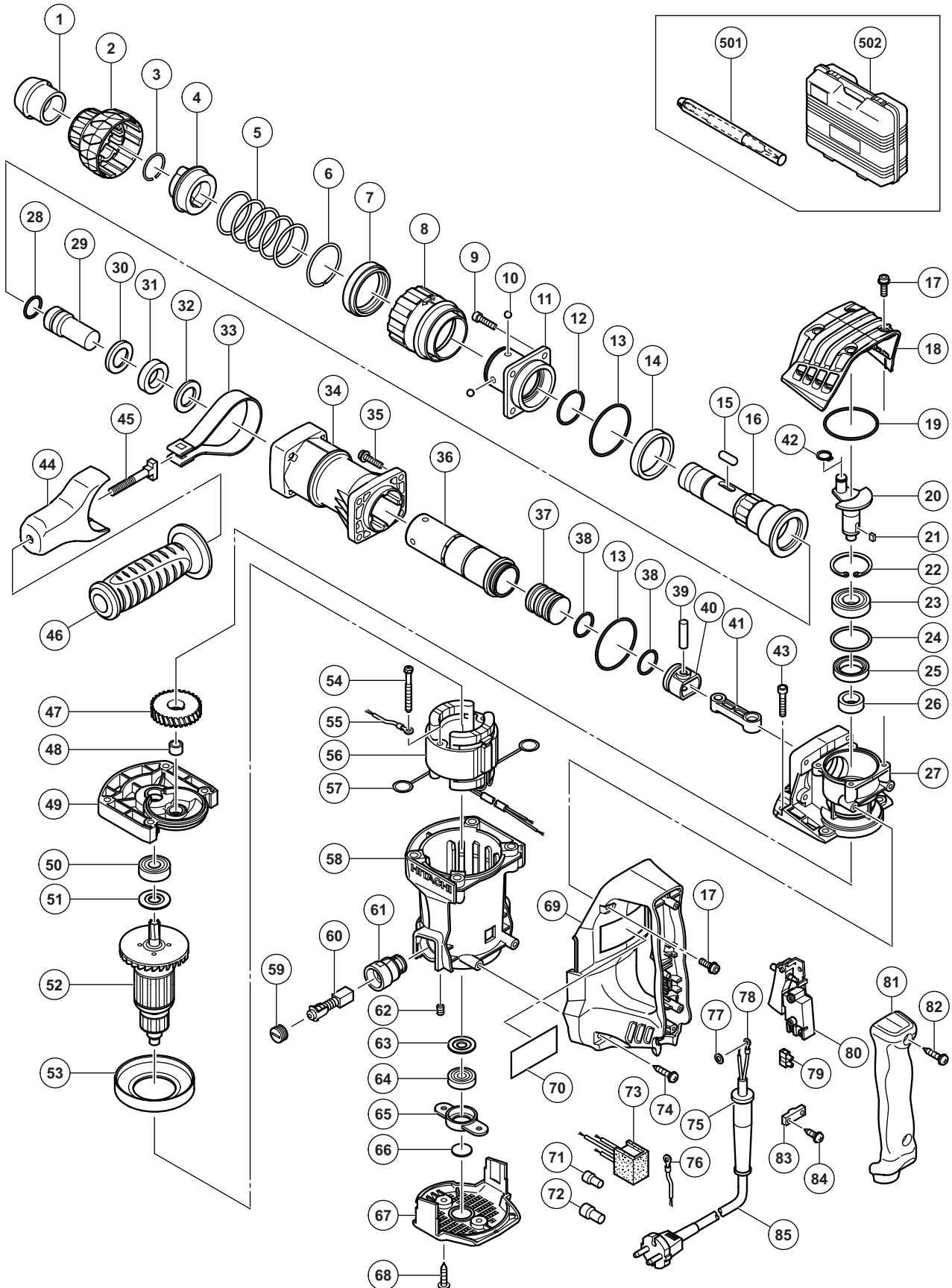

PARTS

H 41MB

ITEM NO.	CODE NO.	DESCRIPTION	NO. USED	REMARKS
1	333-259	FRONT CAP	1	
2	333-258	GRIP (A)	1	
3	333-257	RING	1	
4	331-539	NEEDLE HOLDER	1	
5	333-256	SPRING (A)	1	
6	333-255	STOPPER RING	1	
7	320-810	BALL HOLDER	1	
8	333-254	GRIP (B)	1	
9	981-942	SEAL LOCK HEX. SOCKET HD. BOLT M6 X 25	4	
10	959-150	STEEL BALL D6.35 (10 PCS.)	4	
11	333-248	FRONT COVER	1	
12	980-879	O-RING (S-34)	1	
13	980-715	O-RING (S-48)	2	
14	333-249	RETAINER DAMPER	1	
15	331-536	NEEDLE ROLLER D8 X 20	2	
16	333-250	RETAINER SLEEVE	1	
17	994-192	HEX. SOCKET HD. BOLT (W/FLANGE) M5 X 16	6	
18	333-260	CRANK COVER	1	
19	878-713	CYLINDER O-RING (B)	1	
20	333-244	CRANK SHAFT	1	
21	980-809	FEATHER KEY 4 X 4 X 8	1	
22	948-391	RETAINING RING FOR D40 HOLE	1	
23	620-3DD	BALL BEARING 6203DDCMPS2L	1	
24	996-363	O-RING (S-40)	1	
25	310-119	OIL SEAL	1	
26	333-245	DISTANCE RING	1	
27	333-243	CRANK CASE	1	
28	313-396	O-RING (C)	1	
29	331-525	SECOND HAMMER	1	
30	331-224	DAMPER WASHER	1	
31	321-835	DAMPER	1	
32	331-225	DAMPER HOLDER	1	
33	333-261	BAND	1	
34	333-251	CYLINDER CASE	1	
35	991-712	HEX. SOCKET HD. BOLT (W/FLANGE) M6 X 25	4	
36	333-252	CYLINDER	1	
37	333-253	STRIKER	1	
38	986-104	O-RING	2	
39	980-708	PISTON PIN	1	
40	326-369	PISTON	1	
41	333-247	CONNECTING ROD	1	
42	939-540	RETAINING RING FOR D10 SHAFT (10 PCS.)	1	
43	324-056	SEAL LOCK HEX. SOCKET HD. BOLT M6 X 35	4	
44	333-262	MOUNT	1	
45	333-227	HANDLE BOLT	1	
46	330-209	SIDE HANDLE	1	
47	333-246	FIRST GEAR	1	
48	939-299	NEEDLE BEARING (M661)	1	
49	333-268	GEAR COVER ASS'Y	1	INCLUD. 48
50	620-1DD	BALL BEARING 6201DDCMPS2L	1	

PARTS

H 41MB

ITEM NO.	CODE NO.	DESCRIPTION	NO. USED	REMARKS
51	302-429	DUST WASHER (B)	1	
* 52	360-903C	ARMATURE 110V-115V	1	
* 52	360-903U	ARMATURE ASS'Y 120V	1	INCLUD. 50, 51, 63, 64
* 52	360-903G	ARMATURE 127V	1	
* 52	360-903E	ARMATURE 220V-230V	1	
* 52	360-903F	ARMATURE 240V	1	
53	331-252	FAN GUIDE	1	
54	953-121	HEX. HD. TAPPING SCREW D5 X 50	2	
* 55	990-861	INTERNAL WIRE	1	FOR AUS, NZL, GBR, SAF, EUROPE, FIN, NOR, SWE, DEN, SUI, AUT, CHN, KOR
* 56	340-788A	STATOR ASS'Y 110V	1	INCLUD. 57
* 56	340-788B	STATOR ASS'Y 110V	1	INCLUD. 57 FOR GBR (110V)
* 56	340-788C	STATOR ASS'Y 120V	1	INCLUD. 57
* 56	340-788D	STATOR ASS'Y 127V	1	INCLUD. 57
* 56	340-788F	STATOR ASS'Y 220V-230V	1	INCLUD. 57
* 56	340-788E	STATOR ASS'Y 220V-230V	1	INCLUD.57 FOR THA, INA, SIN, HKG, BRA(220V), PAN (220V), IND
* 56	340-788G	STATOR ASS'Y 240V	1	INCLUD. 57
* 56	340-788H	STATOR ASS'Y 240V	1	INCLUD. 57 FOR AUS
57	930-703	BRUSH TERMINAL	2	
58	333-267	HOUSING ASS'Y	1	INCLUD. 61, 62
59	945-161	BRUSH CAP	2	
* 60	999-043	CARBON BRUSH (1 PAIR)	2	
* 60	999-043	CARBON BRUSH (1 PAIR)	1	EXCEPT FOR VEN, KUW
* 60	999-073	CARBON BRUSH (AUTO STOP TYPE) (1 PAIR)	1	EXCEPT FOR VEN, KUW
61	958-900	BRUSH HOLDER	2	
62	938-477	HEX. SOCKET SET SCREW M5 X 8	2	
63	982-631	WASHER (A)	1	
64	608-VVM	BALL BEARING 608VVC2PS2L	1	
65	331-254	BEARING HOLDER	1	
66	333-263	DUST SEAL	1	
67	333-264	TAIL COVER	1	
68	302-089	TAPPING SCREW (W/FLANGE) D5 X 20 (BLACK)	2	
69	333-265	HANDLE	1	
70		NAME PLATE	1	
* 71	959-140	CONNECTOR 50091 (10 PCS.)	1	FOR AUS, NZL, GBR, SAF, EUROPE, FIN, NOR, SWE, DEN, AUT, SUI, CHN, KOR
* 72	959-141	CONNECTOR 50092 (10 PCS.)	1	EXCEPT FOR USA, CAN, MEX, BRA (127V), PAN (120V)
* 73	331-203	NOISE SUPPRESSOR	1	FOR AUS, NZL, GBR, SAF, EUROPE, FIN, NOR, SWE, DEN, AUT, SUI, CHN, KOR
74	302-089	TAPPING SCREW (W/FLANGE) D5 X 20 (BLACK)	2	
* 75	958-049	CORD ARMOR D8.2	1	
* 75	940-778	CORD ARMOR D10.7	1	
* 76	981-974	INTERNAL WIRE	1	FOR AUS, NZL, GBR, SAF, EUROPE, FIN, NOR, SWE, DEN, AUT, SUI, CHN, KOR
* 77	949-423	WASHER M4 (10 PCS.)	1	FOR AUS, GBR, SAF, EUROPE, FIN, NOR, SWE, DEN, AUT, SUI, CHN, KOR
* 78	980-063	TERMINAL	1	
* 78	930-804	TERMINAL M4.0 (10 PCS.)	1	FOR USA, CAN, MEX, PAN (120V)

