

ELECTRIC TOOL PARTS LIST

■ ELECTRONIC HAND GRINDER Model GP 5V

2011-9-9
(E1)

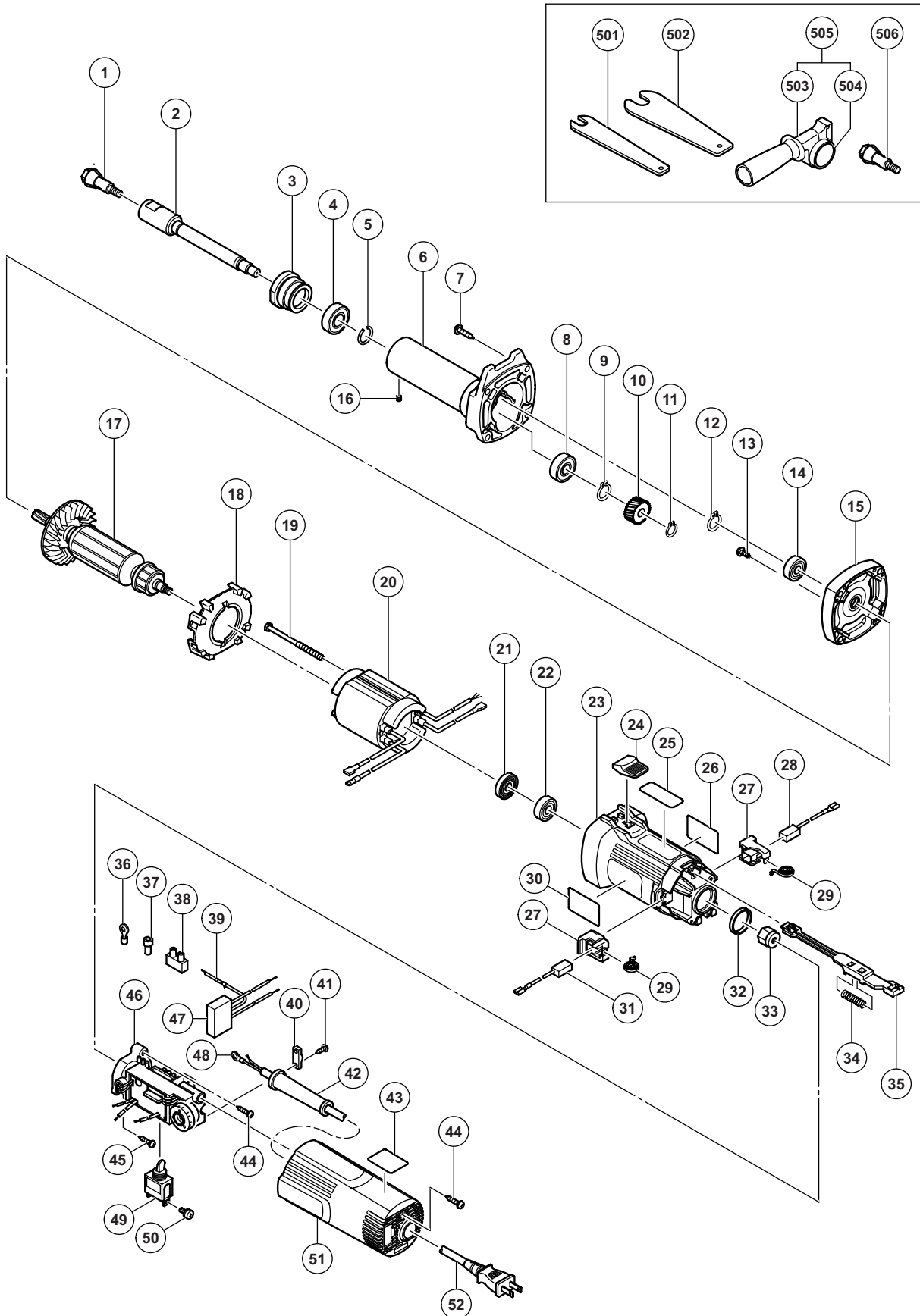

PARTS

GP 5V

ITEM NO.	CODE NO.	DESCRIPTION	NO. USED	REMARKS	
*	1	333-936	COLLET CHUCK 6MM	1	
*	1	331-422	COLLET CHUCK 1/4"	1	FOR AUS, USA, CAN, PAN (120V)
	2	333-644	SPINDLE	1	
	3	332-452	BEARING LID (B)	1	
	4	600-1VV	BALL BEARING 6001VVCMP2L	1	
	5	932-617	RING	1	
	6	333-642	NOSE BRACKET	1	
	7	334-279	TAPPING SCREW (W/SP. WASHER) D5 X 35 (BLACK)	4	
	8	600-0VV	BALL BEARING 6000VVCMP2L	1	
	9	939-540	RETAINING RING FOR D10 SHAFT (10 PCS.)	1	
	10	333-646	FIRST GEAR	1	
	11	940-079	RETAINING RING FOR D8 SHAFT	1	
	12	885-977	RETAINING RING	1	
	13	323-556	SLOTTED HD. SCREW (SEAL LOCK) M4 X 8	2	
	14	609-VVM	BALL BEARING 609VVC2PS2L	1	
	15	333-643	INNER COVER	1	
	16	981-478	HEX. SOCKET SET SCREW M4 X 4	1	
*	17	360-914C	ARMATURE 110V	1	
*	17	360-914U	ARMATURE ASS'Y 120V	1	INCLUD. 14, 21, 22
*	17	360-914G	ARMATURE 127V	1	
*	17	360-914E	ARMATURE 220V-230V	1	
*	17	360-914F	ARMATURE 240V	1	
	18	319-898	FAN GUIDE	1	
	19	982-021	HEX. HD. TAPPING SCREW D4 X 70	2	
*	20	340-827C	STATOR 110V	1	
*	20	340-829C	STATOR 110V (W/CHOKE COIL)	1	FOR GBR (110V)
*	20	340-827D	STATOR 120V-127V	1	
*	20	340-827E	STATOR 220V	1	
*	20	340-829E	STATOR 220V (W/CHOKE COIL)	1	FOR CHN, KOR
*	20	340-827F	STATOR 230V-240V	1	
*	20	340-829F	STATOR 230V-240V (W/CHOKE COIL)	1	FOR AUS, NZL, EUROPE, NOR, SWE, DEN, FIN, SUI, GBR (230V), RUS, AUT, SAF
	21	315-877	DUST SEAL	1	
	22	608-VVM	BALL BEARING 608VVC2PS2L	1	
	23	317-802	HOUSING	1	
	24	314-428	SLIDE KNOB	1	
*	25		CAUTION PLATE	1	FOR USA, CAN
	26		NAME PLATE	1	
	27	317-810	BRUSH HOLDER	2	
	28	999-076	CARBON BRUSH (AUTO STOP TYPE) (1 PAIR)	1	
	29	308-536	SPRING	2	
	30		HITACHI LABEL	1	
	31	999-088	CARBON BRUSH (1 PAIR)	1	
	32	995-662	RUBBER RING	1	
	33	333-933	MAGNET	1	
	34	314-429	SPRING	1	
	35	319-370	SLIDE BAR	1	
	36	930-804	TERMINAL M4.0 (10 PCS.)	1	
	37	959-140	CONNECTOR 50091 (10 PCS.)	1	
	38	938-307	PILLAR TERMINAL	1	
	39	314-854	EARTH TERMINAL	1	

PARTS

ITEM NO.	CODE NO.	DESCRIPTION	NO. USED	REMARKS	
40	937-631	CORD CLIP	1		
41	984-750	TAPPING SCREW (W/FLANGE) D4 X 16	2		
* 42	953-327	CORD ARMOR D8.8	1		
* 42	938-051	CORD ARMOR D10.1	1		
43	333-935	SETTING LABEL (B)	1		
44	301-653	TAPPING SCREW (W/FLANGE) D4 X 20 (BLACK)	2		
45	307-028	TAPPING SCREW (W/FLANGE) D4 X 25 (BLACK)	1		
* 46	333-591	CONTROLLER 100V-120V	1		
* 46	333-593	CONTROLLER 127V	1		
* 46	333-592	CONTROLLER 220V-240V	1		
47	325-566	NOISE SUPPRESSOR	1		
48	980-063	TERMINAL	1	FOR CORD	
49	314-603	SWITCH (1P SOLDER TYPE)	1		
50	305-499	MACHINE SCREW (W/WASHER) M3.5 X 6	2		
51	319-376	TAIL COVER	1		
* 52	500-409Z	CORD	1	(CORD ARMOR D8.8)	
* 52	500-247Z	CORD	1	(CORD ARMOR D8.8) FOR NOR, SWE, DEN, FIN	
* 52	500-237Z	CORD	1	(CORD ARMOR D8.8) FOR GBR (110V), SIN, MAL	
* 52	500-435Z	CORD	1	(CORD ARMOR D8.8) FOR GBR (230V), HKG	
* 52	500-455Z	CORD	1	(CORD ARMOR D8.8) FOR THA, CHN	
* 52	500-439Z	CORD	1	(CORD ARMOR D8.8) FOR AUS, NZL	
* 52	500-240Z	CORD	1	(CORD ARMOR D8.8) FOR USA, CAN	
* 52	323-974	CORD	1	(CORD ARMOR D10.1) FOR UAE	
* 52	500-487Z	CORD	1	(CORD ARMOR D8.8) FOR BRA	
* 52	500-489Z	CORD	1	(CORD ARMOR D8.8) FOR PAN (120V)	
* 52	500-447Z	CORD	1	(CORD ARMOR D8.8) FOR SUI	
* 52	500-234Z	CORD	1	(CORD ARMOR D8.8) FOR KOR	

STANDARD ACCESSORIES

GP 5V

ITEM NO.	CODE NO.	DESCRIPTION	NO. USED	REMARKS
501	936-553	WRENCH 12MM	1	
502	936-638	WRENCH 17MM	1	
503	324-548	SIDE HANDLE	1	
504	330-061	FLANGED SLEEVE	1	
505	330-060	SIDE HANDLE SLEEVE ASS'Y	1	INCLUD. 503, 504
* 506	331-477	COLLET CHUCK 5/16"	1	FOR NOR, SWE, DEN, FIN

OPTIONAL ACCESSORIES

ITEM NO.	CODE NO.	DESCRIPTION	NO. USED	REMARKS
* 601	939-100	MOUNTED WHEELS KA-1 D6 SHAFT (10 PCS.)	1	EXCEPT FOR USA, CAN
* 602	939-101	MOUNTED WHEELS KA-2 D6 SHAFT (10 PCS.)	1	EXCEPT FOR USA, CAN
* 603	939-102	MOUNTED WHEELS KA-3 D6 SHAFT (10 PCS.)	1	EXCEPT FOR USA, CAN
* 604	939-103	MOUNTED WHEELS KA-4 D6 SHAFT (10 PCS.)	1	EXCEPT FOR USA, CAN
* 605	939-104	MOUNTED WHEELS KA-5 D6 SHAFT (10 PCS.)	1	EXCEPT FOR USA, CAN
* 606	939-105	MOUNTED WHEELS KA-6 D6 SHAFT (10 PCS.)	1	EXCEPT FOR USA, CAN
* 607	939-106	MOUNTED WHEELS KA-7 D6 SHAFT (10 PCS.)	1	EXCEPT FOR USA, CAN
* 608	939-107	MOUNTED WHEELS KA-8 D6 SHAFT (10 PCS.)	1	EXCEPT FOR USA, CAN
* 609	939-108	MOUNTED WHEELS KA-9 D6 SHAFT (10 PCS.)	1	EXCEPT FOR USA, CAN
* 610	939-109	MOUNTED WHEELS KA-10 D6 SHAFT (10 PCS.)	1	EXCEPT FOR USA, CAN
* 611	949-023	MOUNTED WHEELS KA-11 D6 SHAFT (10 PCS.)	1	EXCEPT FOR USA, CAN
* 612	949-021	MOUNTED WHEELS KA-12 D6 SHAFT (10 PCS.)	1	EXCEPT FOR USA, CAN
* 613	949-022	MOUNTED WHEELS KA-13 D6 SHAFT (10 PCS.)	1	EXCEPT FOR USA, CAN
* 614	939-110	MOUNTED WHEELS KA-20 D3 SHAFT (20 PCS.)	1	EXCEPT FOR USA, CAN
* 615	939-111	MOUNTED WHEELS KA-21 D3 SHAFT (20 PCS.)	1	EXCEPT FOR USA, CAN
* 616	939-112	MOUNTED WHEELS KA-22 D3 SHAFT (20 PCS.)	1	EXCEPT FOR USA, CAN
* 617	939-113	MOUNTED WHEELS KA-23 D3 SHAFT (20 PCS.)	1	EXCEPT FOR USA, CAN
* 618	939-114	MOUNTED WHEELS KA-24 D3 SHAFT (20 PCS.)	1	EXCEPT FOR USA, CAN
* 619	939-115	MOUNTED WHEELS KC-20 D3 SHAFT (20 PCS.)	1	EXCEPT FOR USA, CAN
* 620	939-116	MOUNTED WHEELS KC-21 D3 SHAFT (20 PCS.)	1	EXCEPT FOR USA, CAN
* 621	939-117	MOUNTED WHEELS KC-22 D3 SHAFT (20 PCS.)	1	EXCEPT FOR USA, CAN
* 622	939-118	MOUNTED WHEELS KC-23 D3 SHAFT (20 PCS.)	1	EXCEPT FOR USA, CAN
* 623	939-119	MOUNTED WHEELS KC-24 D3 SHAFT (20 PCS.)	1	EXCEPT FOR USA, CAN
624	939-120	DRESSER C36PV	1	
625	331-477	COLLET CHUCK 5/16"	1	
626	932-624	COLLET CHUCK 3MM	1	
627	985-136	COLLET CHUCK 1/8"	1	
* 628	332-812	COLLET CHUCK 6MM	1	EXCEPT FOR USA, CAN