

HITACHI

LIST NO. E212

ELECTRIC TOOL PARTS LIST

■ DISC GRINDER
Model G 23U

1993 · 3 · 25
(E1)

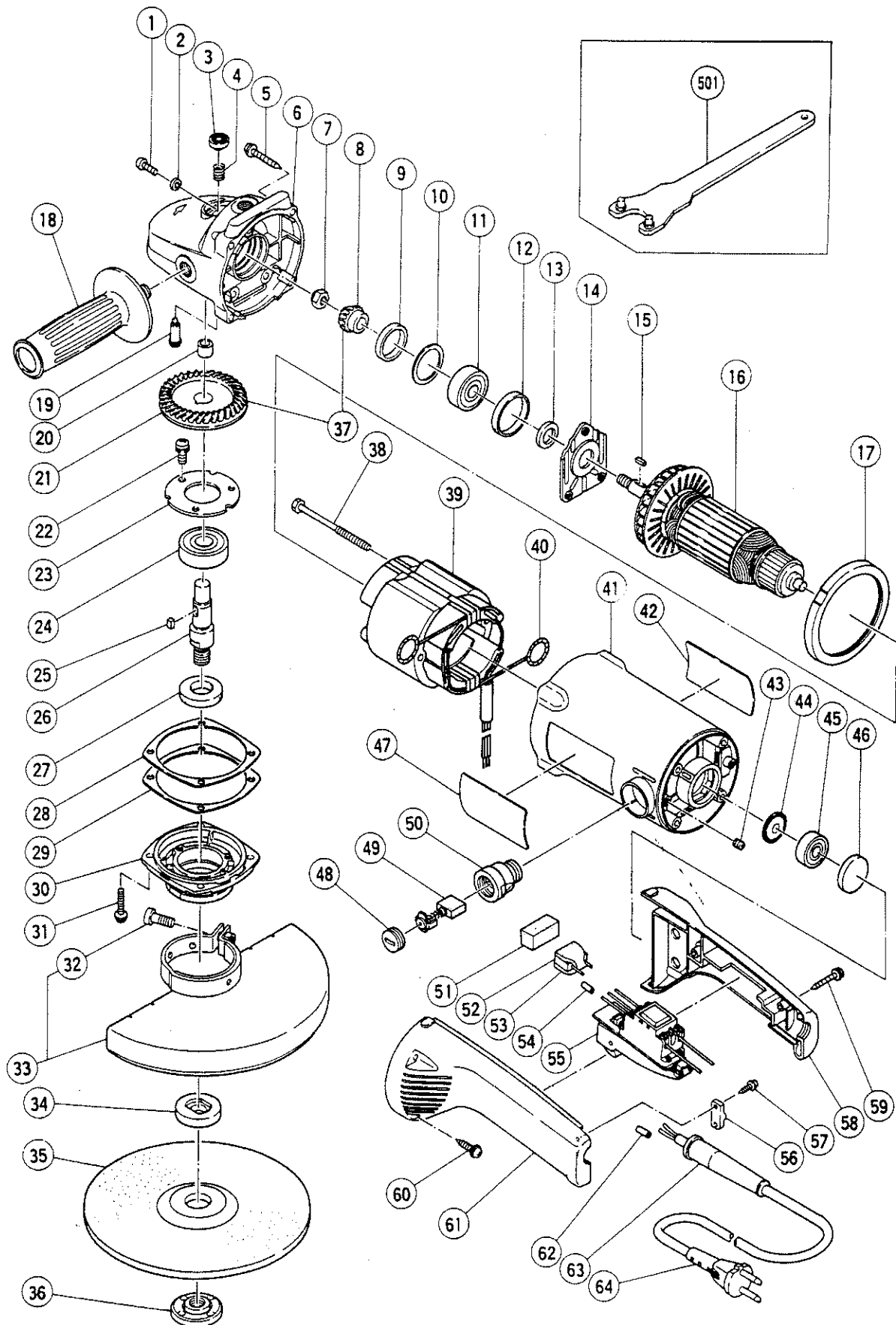

PARTS

G 23U

ITEM NO.	CODE NO.	DESCRIPTION	NO. USED	REMARKS
1	949-238	MACHINE SCREW M5X14 (10 PCS.)	3	
2	949-454	SPRING WASHER M5 (10 PCS.)	3	
3	306-888	PUSH BUTTON	1	
4	306-889	SPRING	1	
5	301-854	TAPPING SCREW (W/FLANGE) D5X35	4	
6	308-105	GEAR COVER ASS'Y	1	INCLUD.3,4,19,20
7	946-228	U - NUT M8	1	
8	306-110	PINION	1	
9	306-107	SEAL RING (A)	1	
10	306-113	WASHER (A)	1	
11	630-1DD	BALL BEARING 6301DDUCMPS2S	1	
12	994-208	RUBBER RING (B)	1	
13	990-864	FELT PACKING (A)	1	
14	306-106	BEARING COVER	1	
15	940-533	FEATHER KEY 3X3X10	1	
16	360-288E	ARMATURE 220V - 240V	1	
17	306-103	FAN GUIDE	1	
18	937-981Z	SIDE HANDLE FOR M14	1	
19	306-890	LOCK PIN	1	
20	673-002	NEEDLE BEARING (HK1212)	1	
21	306-109	GEAR	1	
22	992-038	SEAL LOCK SCREW (W/SP. WASHER) MSX10	3	
23	937-035	BEARING COVER (B)	1	
24	630-2DD	BALL BEARING 6302DDUCMPS2S	1	
25	980-809	FEATHER KEY 4X4X8	1	
26	990-857	SPINDLE	1	
27	990-852	FELT PACKING (B)	1	
28	306-112	SEAL PLATE	1	
29	306-981	THRUST WASHER	1	
30	306-111	PACKING GLAND	1	
31	994-192	HEX. SOCKET HD. BOLT (W/FLANGE) MSX16	4	
32	306-887	BOLT M8X22	1	
33	306-120	WHEEL GUARD ASS'Y	1	INCLUD.32
34	937-907Z	WHEEL WASHER (A)	1	
35	937-910Z	D. C. WHEELS 230MM A24R (10 PCS.)	1	
36	937-909Z	WHEEL NUT M14X2	1	
37	306-108	GEAR ASS'Y	1	INCLUD.8,21
38	961-501	HEX. HD. TAPPING SCREW D5X60	2	
39	340-282E	STATOR ASS'Y 230V	1	INCLUD.40
39	340-282F	STATOR ASS'Y 240V	1	INCLUD.40
40	958-032	BRUSH TERMINAL	2	
41	306-812	HOUSING ASS'Y	1	INCLUD.43,50
42		NAME PLATE	1	
43	938-477	HEX. SOCKET SET SCREW M5X8	2	
44	955-260	DUST SEAL (A)	1	
45	620-0VV	BALL BEARING 6200VVCMP2S	1	
46	306-104	RUBBER RING (D) 3/3485	1	
47		HITACHI LABEL	1	
48	940-540	BRUSH CAP	2	
49	999-044	CARBON BRUSH (1 PAIR)	2	
50	980-487	BRUSH HOLDER	2	

*: ALTERNATIVE PARTS

3-93

PARTS

G 23U

ITEM NO.	CODE NO.	DESCRIPTION	NO. USED	REMARKS
51	308-117	DUST PACKING	1	
52	984-273	NOISE SUPPRESSOR	1	
53	308-114	SUPPORT (B)	1	
54	981-373	TUBE (D)	3	
* 55	307-649	SWITCH (2P PILLAR TYPE) W/SAFETY LOCK	1	W/LOCK
* 55	307-650	SWITCH (2P PILLAR TYPE) W/SAFETY LOCK	1	W/O LOCK FOR GBR
56	960-266	CORD CLIP	1	
57	984-750	TAPPING SCREW (W/FLANGE) D4X16	2	
58	308-119	HANDLE (B)	1	
59	304-035	TAPPING SCREW (W/FLANGE) D4X25 (BLACK)	2	
60	305-558	TAPPING SCREW (W/FLANGE) D5X25 (BLACK)	4	
61	308-118	HANDLE (A)	1	
* 62	981-373	TUBE (D)	2	FOR CORD
63	940-778	CORD ARMOR D10.7	1	
* 64	500-247Z	CORD	1	
* 64	500-248Z	CORD	1	FOR GBR
* 64	500-248Z	CORD	1	FOR SUI

STANDARD ACCESSORIES

ITEM NO.	CODE NO.	DESCRIPTION	NO. USED	REMARKS
501	937-913Z	WRENCH	1	

OPTIONAL ACCESSORIES

ITEM NO.	CODE NO.	DESCRIPTION	NO. USED	REMARKS
601	937-943Z	CARBON BRUSH (AUTO STOP TYPE) (1 PAIR)	2	

* : ALTERNATIVE PARTS