

ELECTRIC TOOL PARTS LIST

■ DISC GRINDER
Model G 23SE

1996 · 10 · 21
(E2)

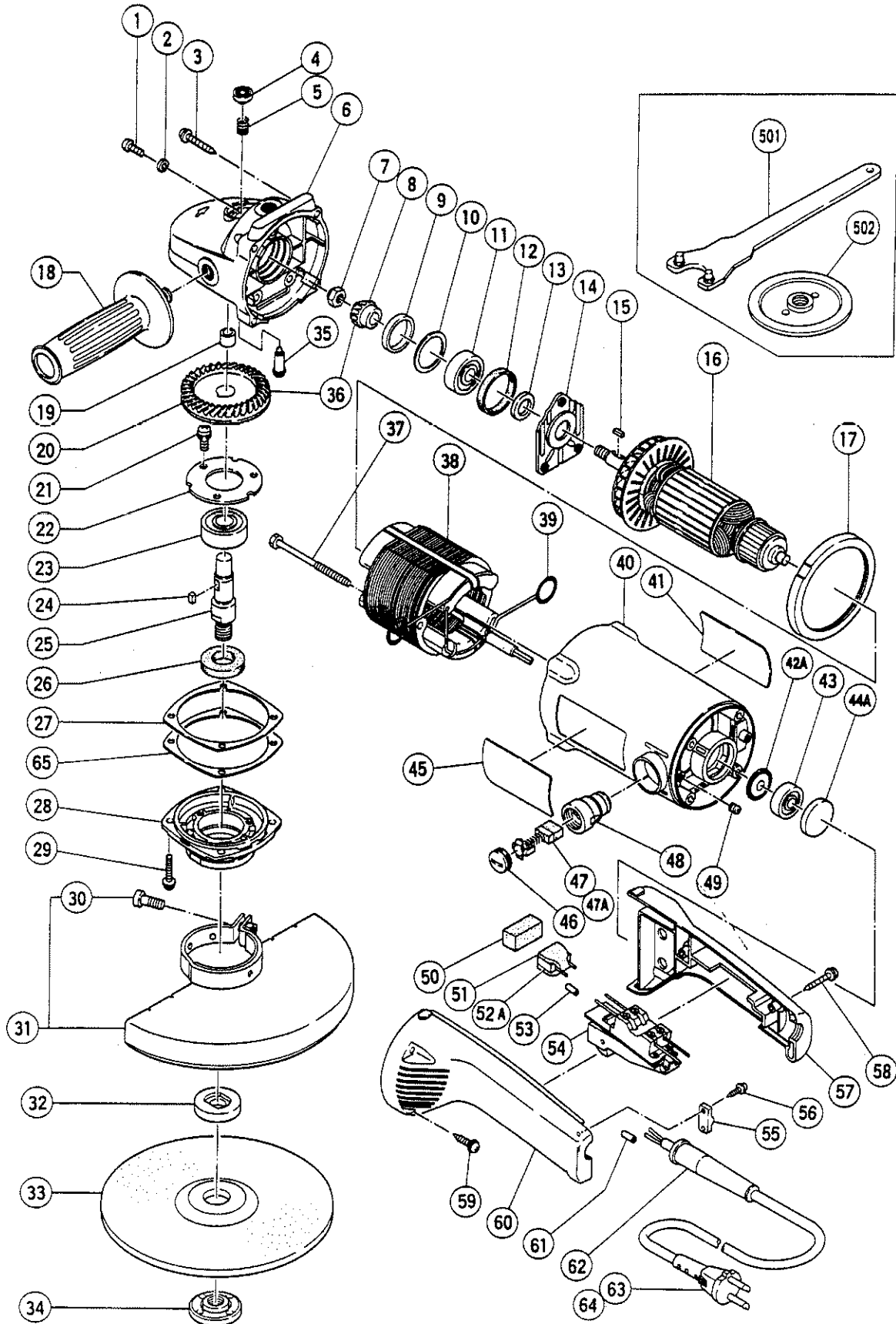

PARTS

G 23SE

ITEM NO.	CODE NO.	DESCRIPTION	NO. USED	REMARKS
1	949-238	MACHINE SCREW M5X14 (10 PCS.)	3	
2	949-454	SPRING WASHER M5 (10 PCS.)	3	
3	301-654	TAPPING SCREW (W/FLANGE) D5X35	4	
4	306-888	PUSHING BUTTON	1	
5	306-889	SPRING	1	
6	306-105	GEAR COVER ASS'Y	1	INCLUD.4.5.19.35
7	946-228	U - NUT M8	1	
8	306-110	PINION	1	
9	306-107	SEAL RING (A)	1	
10	306-113	WASHER (A)	1	
11	630-1DD	BALL BEARING 6301DDUCMPS2S	1	
12	994-208	RUBBER RING (B)	1	
13	990-884	FELT PACKING (A)	1	
14	306-106	BEARING COVER	1	
15	940-533	FEATHER KEY 3X3X10	1	
* 16	360-287C	ARMATURE 100V - 115V	1	
16	360-287E	ARMATURE 220V - 230V	1	
16	360-287F	ARMATURE 240V	1	
17	306-103	FAN GUIDE	1	
18	937-981	SIDE HANDLE FOR M14	1	
19	673-002	NEEDLE BEARING (HK1212)	1	
20	306-109	GEAR	1	
21	992-038	SEAL LOCK SCREW (W/SP. WASHER) M5X10	3	
22	937-035	BEARING COVER (B)	1	
23	630-2DD	BALL BEARING 6302DDUCMPS2S	1	
24	980-809	FEATHER KEY 4X4X8	1	
25	990-857	SPINDLE	1	
26	990-852	FELT PACKING (B)	1	
27	306-112	SEAL PLATE	1	
28	306-111	PACKING GLAND	1	
29	994-192	HEX. SOCKET HD. BOLT (W/FLANGE) M5X16	4	
30	306-887	BOLT M8X22	1	
31	306-120	WHEEL GUARD ASS'Y	1	INCLUD.30
* 32	937-907Z	WHEEL WASHER (A)	1	
* 32	937-908Z	WHEEL WASHER (B)	1	FOR AUS,NZL
* 33	937-910Z	D. C. WHEELS 230MM A24R (10 PCS.)	1	FOR SAF,AUS
34	937-909Z	WHEEL NUT M14X2	1	
35	306-890	LOCK PIN	1	
36	306-108	GEAR PINION ASS'Y	1	INCLUD.8.20
37	984-271	HEX. HD. TAPPING SCREW D5X75	2	
* 38	340-260E	STATOR ASS'Y 220V - 230V	1	INCLUD.39
* 38	340-261G	STATOR ASS'Y 110V	1	INCLUD.39
* 38	340-260G	STATOR ASS'Y 230V	1	INCLUD.39 FOR NZL,SAF,ITA,FRG,FRA,HOL, DEN,FIN,SWE,NOR
* 38	340-260F	STATOR ASS'Y 240V	1	INCLUD.39 FOR AUS
39	958-032	BRUSH TERMINAL	2	
40	306-102	HOUSING ASS'Y	1	INCLUD.48,49
41		NAME PLATE	1	
42A	310-998	DUST SEAL	1	
43	620-0VV	BALL BEARING 6200VVCMP2S	1	
44A	313-485	RUBBER RING (E)	1	

*: ALTERNATIVE PARTS

PARTS

G 23SE

ITEM NO.	CODE NO.	DESCRIPTION	NO. USED	REMARKS
45		HITACHI LABEL	1	
46	940-540	BRUSH CAP	2	
47	998-044	CARBON BRUSH (1 PAIR)	2	
47A	937-943Z	CARBON BRUSH (AUTO STOP TYPE) (1 PAIR)	2	FOR ESP
48	980-487	BRUSH HOLDER	2	
49	938-477	HEX. SOCKET SET SCREW M5X8	2	
50	306-117	DUST PACKING	1	
51	306-114	SUPPORT (B)	1	FOR NOISE SUPPRESSOR
52A	930-039	NOISE SUPPRESSOR	1	FOR GBR,SAF,ITA,FRG,FRA,HOL,DEN,FIN,SWE, NOR,ESP
53	961-820	TUBE (D)	2	FOR NOISE SUPPRESSOR
54	306-115	SWITCH (2P PILLAR TYPE) W/SAFETY LOCK	1	W/O LOCK
54	306-118	SWITCH (2P PILLAR TYPE) W/SAFETY LOCK	1	W/LOCK FOR SAF,FRG,HOL,DEN,SWE,ESP
55	960-266	CORD CLIP	1	
56	984-750	TAPPING SCREW (W/FLANGE) D4X16	2	
57	306-119	HANDLE (B)	1	
58	304-035	TAPPING SCREW (W/FLANGE) D4X25 (BLACK)	2	
59	305-558	TAPPING SCREW (W/FLANGE) D5X25 (BLACK)	4	
60	306-118	HANDLE (A)	1	
61	981-373	TUBE (D)	2	FOR CORD
62	958-049	CORD ARMOR D8.2	1	
62	940-778	CORD ARMOR D10.7	1	
63	500-438Z	CORD	1	(CORD ARMOR D10.7)
63	500-246Z	CORD	1	(CORD ARMOR D10.7) FOR GBR
63	500-411Z	CORD	1	(CORD ARMOR D10.7) FOR AUS
64	938-333Z	CORD	1	(CORD ARMOR D8.2) FOR SAF
65	306-881	THRUST WASHER	1	

STANDARD ACCESSORIES

ITEM NO.	CODE NO.	DESCRIPTION	NO. USED	REMARKS
501	937-913Z	WRENCH	1	
502	937-917Z	WHEEL NUT (B)	1	(DIAMOND WHEEL) FOR AUS,NZL

OPTIONAL ACCESSORIES

ITEM NO.	CODE NO.	DESCRIPTION	NO. USED	REMARKS
601	937-910Z	D. C. WHEELS 230MM A24R (10 PCS.)	1	
602	937-943Z	CARBON BRUSH (AUTO STOP TYPE) (1 PAIR)	2	
603	994-275	DIAMOND WHEEL (SEGMENT) 230MM - D22.2 HOLE	1	FOR CONCRETE
604	994-276	DIAMOND WHEEL 230MM - D22.2 HOLE	1	WAVE SHAPE TYPE FOR CONCRETE
605	994-277	DIAMOND WHEEL (SEGMENT) 230MM - D22.2 HOLE	1	FOR ABRASIVE MATERIALS
606	994-278	DIAMOND WHEEL (SEGMENT) 230MM - D22.2 HOLE	1	FOR CONCRETE
607	310-337	SUPERWASHER	1	

* : ALTERNATIVE PARTS