

ELECTRIC TOOL PARTS LIST

■ IMPACT DRILL

2004 • 1 • 15

Model FDV 16VB2

(E1)

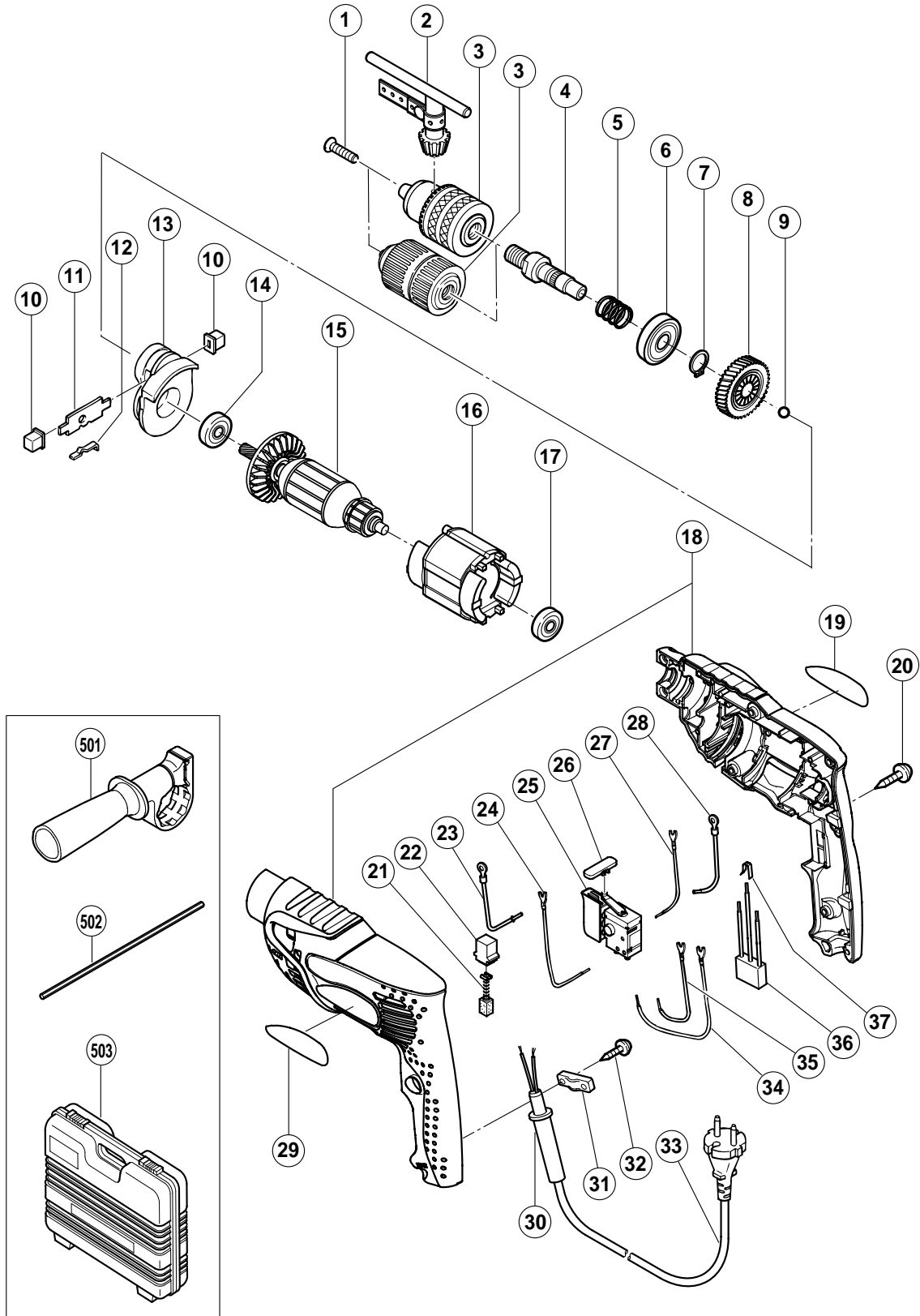

PARTS

FDV 16VB2

ITEM NO.	CODE NO.	DESCRIPTION	NO. USED	REMARKS
1	995-344	FLAT HD. SCREW (A) (LEFT HAND) M6X25	1	
* 2	987-576	CHUCK WRENCH FOR 13VLB-D,13VLR-D	1	
* 3		DRILL CHUCK 13VLRB-D	1	INCLUD. 2 SUPPLIED WITH ITEM NO. 601
* 3	322-625	DRILL CHUCK 13VLRJ-N (W/O CHUCK WRENCH)	1	
4	316-093	SPINDLE	1	
5	303-651	SPRING	1	
6	620-1VV	BALL BEARING 6201VVCMP2L	1	
7	939-542	RETAINING RING FOR D12 SHAFT (10 PCS.)	1	
8	317-482	GEAR	1	
9	959-149	STEEL BALL D4.76 (10 PCS.)	1	
10	319-604	CHANGE KNOB	2	
11	963-224	CHANGE PLATE	1	
12	963-226	SPRING (A)	1	
13	316-094	HOLDER	1	
14	608-VVM	BALL BEARING 608VVC2PS2L	1	
* 15	360-327U	ARMATURE ASS'Y 110V-120V	1	INCLUD. 14, 17
* 15	360-207E	ARMATURE 220V-230V	1	
* 15	360-207F	ARMATURE 230V-240V	1	FOR KUW, AUS
* 16	340-221	STATOR 100V-120V	1	
* 16	340-222E	STATOR 220V	1	
* 16	340-222F	STATOR 230V-240V	1	
17	626-VVM	BALL BEARING 626VVC2PS2L	1	
* 18	322-421	HOUSING (A).(B) SET (GREEN)	1	
* 18	322-626	HOUSING (A).(B) SET (MOSS GREEN)	1	
* 18	322-423	HOUSING (A).(B) SET (OFF BLACK GREEN)	1	
19		NAME PLATE	1	
20	302-086	TAPPING SCREW (W/FLANGE) D4X20 (BLACK)	7	
21	999-041	CARBON BRUSH (1 PAIR)	2	
* 22	930-483	BRUSH HOLDER	2	
* 22	955-203	BRUSH HOLDER	2	FOR USA, CAN
* 23	322-426	CHOKE COIL (BLUE)	1	FOR NZL, AUS, SAF, EUROPE, SUI, GBR (230V), CHN
* 23	322-427	CHOKE COIL (BLUE)	1	FOR TPE
* 23	322-429	INTERNAL WIRE (BLUE)	1	FOR THA, INA, IND, SIN, KUW, HKG, GBR (110V)
* 23	322-420	INTERNAL WIRE (BLUE)	1	FOR USA,CAN
24	322-418	INTERNAL WIRE (WHITE)	1	
25	321-632	SWITCH (1P PILLAR TYPE)	1	
26	321-628	PUSHING BUTTON	1	
27	322-417	INTERNAL WIRE (BLACK)	1	
* 28	322-424	CHOKE COIL (BROWN)	1	FOR NZL, AUS, SAF, EUROPE, SUI, GBR (230V), CHN
* 28	322-425	CHOKE COIL (BROWN)	1	FOR TPE
* 28	322-428	INTERNAL WIRE (BROWN)	1	FOR THA, INA, IND, SIN, KUW, HKG, GBR (110V)
* 28	322-419	INTERNAL WIRE (BROWN)	1	FOR USA, CAN
29		HITACHI LABEL	1	
* 30	307-217	CORD ARMOR D7.2	1	
* 30	303-662	CORD ARMOR D8.8	1	
31	960-266	CORD CLIP	1	
32	305-812	TAPPING SCREW (W/FLANGE) D4X16 (BLACK)	2	
* 33	303-667	CORD	1	
* 33	500-409Z	CORD	1	(CORD ARMOR D8.8) FOR INA, IND, SAF, EUROPE
* 33	500-423Z	CORD	1	(CORD ARMOR D8.8) FOR SIN, KUW
* 33	500-439Z	CORD	1	(CORD ARMOR D8.8) FOR NZL, AUS

