

HITACHI

LIST NO. 0175

ELECTRIC TOOL PARTS LIST

■ SUPER DRILL
Model DW 15Y

1994 • 2 • 8
(E5)

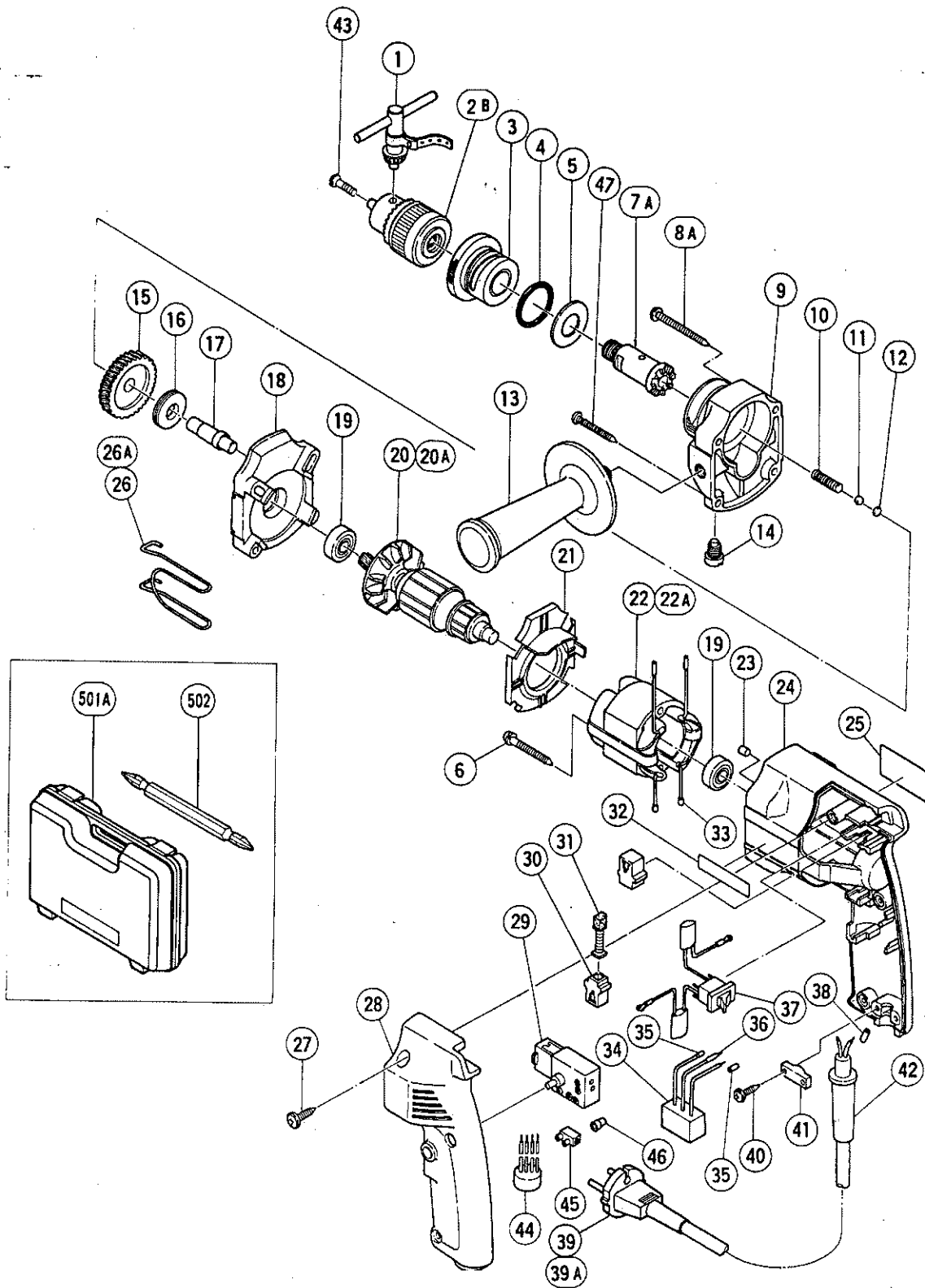

PARTS

DW 15Y

ITEM NO.	CODE NO.	DESCRIPTION	NO. USED	REMARKS
1	930-119	CHUCK WRENCH 6.5G	1	
2B	950-256	DRILL CHUCK 10VLR	1	INCLUD.1,43
3	950-521	CLUTCH RING ASS'Y	1	INCLUD.4
4	873-731	O - RING (S - 28)	1	
5	950-513	WASHER	2	
6	992-630	TAPPING SCREW (W/SP. WASHER) D4X40	2	
7A	950-512	SPINDLE	1	
8A	950-515	TAPPING SCREW D4X50	2	
9	950-516	GEAR COVER	1	
10	943-614	SPRING (A)	1	
11	959-154	STEEL BALL D5.556 (10 PCS.)	1	
12	950-539	PLATE	1	
13	954-672	SIDE HANDLE	1	
14	950-519	STOP SCREW	1	
15	950-510	GEAR	1	
16	950-508	THRUST NEEDLE BEARING (NTN AS1101)	1	
17	950-509	GEAR SHAFT	1	
18	950-507	INNER COVER	1	
19	608-VVM	BALL BEARING 608VVMC2EPS2L	2	
* 20	992-640	ARMATURE 100V - 115V	1	
* 20	992-640E	ARMATURE 220V - 230V	1	
* 20	992-640F	ARMATURE 240V	1	
* 20A	360-203E	ARMATURE 220V - 230V	1	FOR FRG,FRA,ITA,HOL,DEN,SWE
21	950-504	FAN GUIDE	1	
* 22	992-639C	STATOR ASS'Y 110V - 115V	1	INCLUD.33
* 22	992-639E	STATOR ASS'Y 220V - 230V	1	INCLUD.33
* 22	992-639F	STATOR ASS'Y 240V	1	INCLUD.33
* 22	992-639G	STATOR ASS'Y 220V - 230V	1	INCLUD.33 FOR NOR
* 22	992-639N	STATOR ASS'Y 220V - 230V	1	INCLUD.33 FOR SUI
* 22	992-639L	STATOR ASS'Y 220V - 230V	1	INCLUD.33 FOR NZL
* 22	992-639H	STATOR ASS'Y 240V	1	INCLUD.33 FOR GBR
* 22	992-639M	STATOR ASS'Y 110V	1	INCLUD.33 FOR GBR
* 22A	340-218G	STATOR ASS'Y 220V - 230V	1	INCLUD.33 FOR ITA,HOL,DEN,SWE
* 22A	340-218L	STATOR ASS'Y 220V - 230V	1	INCLUD.33 FOR FRG,FRA
23	931-701	BEARING LOCK	1	
24	991-880	HOUSING	1	
25		NAME PLATE	1	
* 26	950-511	HOOK	1	
* 26A	950-551	HOOK	1	FOR ITA,FRG,FRA,HOL,DEN,SWE
27	982-095	TAPPING SCREW (W/WASHER) D4X20	3	
28	991-885	HANDLE COVER	1	
* 29	986-114	SWITCH (F) (2P PILLAR TYPE) W/LOCK	1	110V - 127V
* 29	950-991Z	SWITCH (2P PILLAR TYPE) W/LOCK	1	220V - 240V
30	930-483	BRUSH HOLDER	2	
31	999-041	CARBON BRUSH (1 PAIR)	2	
32	950-585	HITACHI LABEL	1	
* 33	981-373	TUBE (D)	2	FOR STATOR
* 34	984-273	NOISE SUPPRESSOR	1	
* 35	981-373	TUBE (D)	2	FOR NOISE SUPPRESSOR
* 36	992-635	EARTH TERMINAL	1	FOR NOISE SUPPRESSOR
* 37	992-636	REVERSING SWITCH	1	

*: ALTERNATIVE PARTS

STANDARD ACCESSORIES

DW 15Y

ITEM NO.	CODE NO.	DESCRIPTION	NO. USED	REMARKS
501A	998-780	CASE (PLASTIC)	1	
502	983-008	+ DRIVER BIT NO.2 65L	1	

OPTIONAL ACCESSORIES

ITEM NO.	CODE NO.	DESCRIPTION	NO. USED	REMARKS
601	983-004	+ DRIVER BIT NO.1 65L	1	
602	983-011	+ DRIVER BIT NO.3 65L	1	
603	955-656	- DRIVER BIT (A) 3MMX50L	1	
604	955-658	- DRIVER BIT (A) 4MMX50L	1	
605	955-673	- DRIVER BIT (A) 6MMX50L	1	
606	955-675	HEX. SOCKET (A) M3X55L (H5.5MM)	1	
607	955-676	HEX. SOCKET (A) M4X55L (H7MM)	1	
608	955-677	HEX. SOCKET (A) M5X55L (H8MM)	1	
609	955-678	HEX. SOCKET (A) M6X55L (H10MM)	1	
610	955-679	HEX. SOCKET (A) M8X55L (H13MM)	1	
611	955-242	HEX. SOCKET (A) M6X55L (H9.7MM)	1	
612	950-532	HEX. BIT 4MM	1	
613	950-533	HEX. BIT 5MM	1	
614	950-534	HEX. BIT 6MM	1	
615	950-535	HEX. BIT 8MM	1	
616	954-321	RUBBER PAD	1	
617	954-322	ARBOR SET ASS'Y	1	INCLUD.618 - 620
618	954-324	CONE WASHER	1	
619	954-323	WASHER	1	
620	949-794	FLAT HD. SCREW M6X20 (10 PCS.)	1	
621	939-015	SANDING DISCS 130MM WA50 (3 PCS.)	1	
622	939-016	SANDING DISCS 130MM WA80 (3 PCS.)	1	
623	939-017	SANDING DISCS 130MM WA120 (3 PCS.)	1	
624	939-530	ROTARY FILE (COLUMN TYPE)	1	
625	939-531	ROTARY FILE (CONE TYPE)	1	
626	939-532	ROTARY FILE (BALL TYPE)	1	
627	943-761	SQUARE DRILL BIT	1	
628	950-536	DRILL TIP	1	
629	939-520	WOOL BONNET 125MM	1	

*: ALTERNATIVE PARTS

