

ELECTRIC TOOL PARTS LIST

CORDLESS DRIVER DRILL
Model DS 18DVC

2010·6·3
(E1)

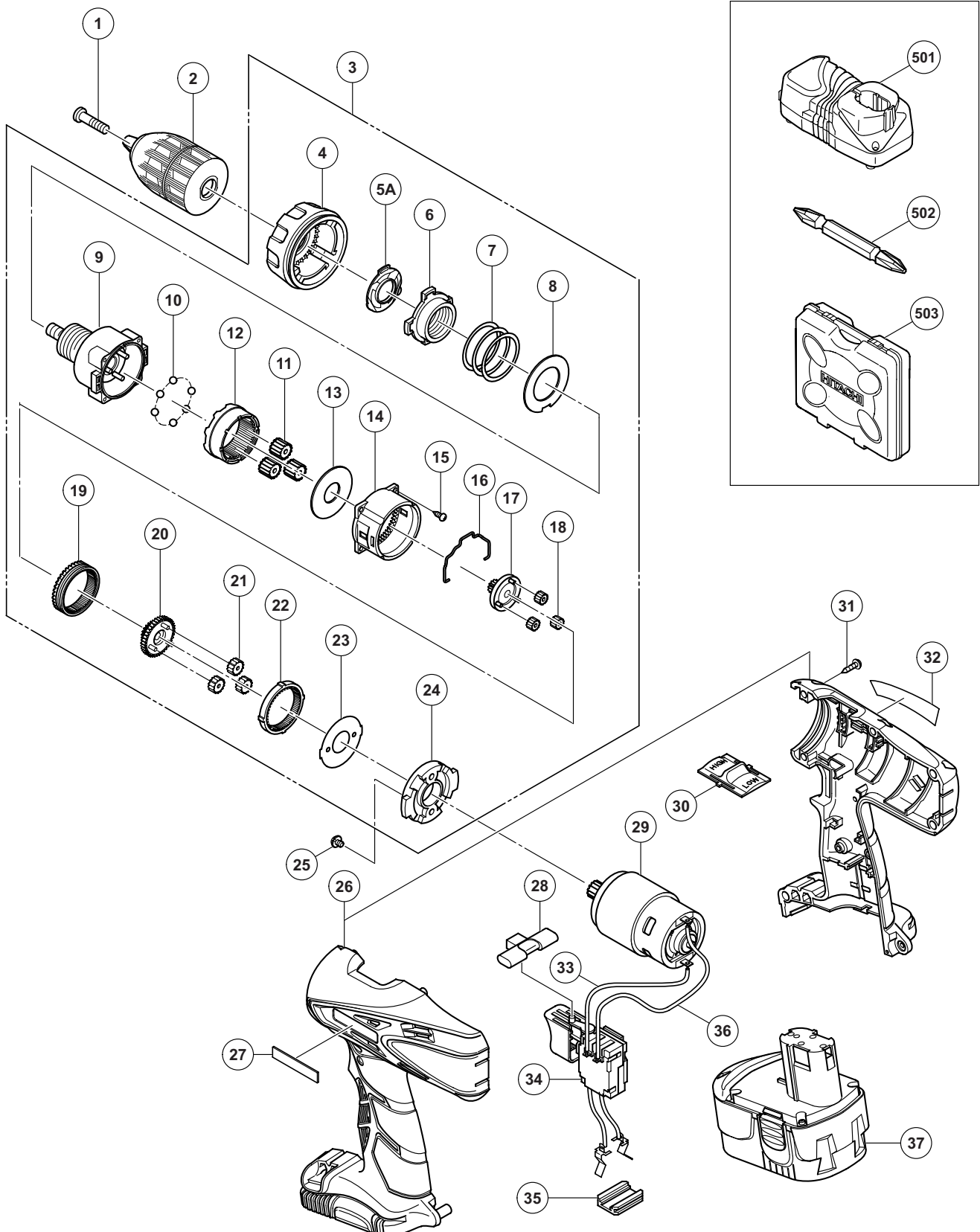

PARTS

DS 18DVC

ITEM NO.	CODE NO.	DESCRIPTION	NO. USED	REMARKS
1	311-959	SPECIAL SCREW (LEFT HAND) M6 X 23	1	
* 2	332-049	DRILL CHUCK 13VLRN-N	1	
* 2	332-040	DRILL CHUCK 13VLRN-N	1	FOR USA, CAN
3	332-024	GEAR BOX ASS'Y	1	INCLUD. 4-24
4	332-025	CLUTCH DIAL	1	
5A	332-741	CLICK SPRING	1	
6	324-109	NUT	1	
7	324-110	SPRING	1	
8	324-347	WASHER (D)	1	
9	332-026	FRONT CASE	1	
10	306-936	STEEL BALL D5	6	
11	332-028	PLANET GEAR (C) SET (3 PCS.)	3	
12	332-027	RING GEAR	1	
13	324-349	WASHER (A)	1	
14	324-501	REAR CASE	1	
15	324-357	SCREW SET D3 X 12 (4 PCS.)	4	
16	324-115	SHIFT ARM	1	
17	332-029	PINION (C)	1	
18	332-031	PLANET GEAR (B) SET (3 PCS.)	3	
19	332-030	SLIDE RING GEAR (B)	1	
20	332-032	PINION (B)	1	
21	332-034	PLANET GEAR (A) SET (3 PCS.)	3	
22	332-033	FIRST RING GEAR	1	
23	324-355	WASHER (B)	1	
24	324-495	MOTOR SPACER	1	
25	317-333	MACHINE SCREW (W/SP. WASHER) M4 X 6	2	
26	332-039	HOUSING (A) (B) SET (GREEN)	1	
27	330-719	HITACHI LABEL	1	
28	332-836	PUSHING BUTTON	1	
29	332-558	MOTOR DC 18V	1	
30	332-036	SHIFT KNOB	1	
31	313-687	TAPPING SCREW (W/FLANGE) D3 X 16 (BLACK)	9	
32		NAME PLATE	1	
33	332-843	INTERNAL WIRE (BLACK) 130L	1	
34	332-038	SWITCH TERMINAL	1	
35	315-141	TERMINAL SUPPORT (A)	1	
36	324-499	INTERNAL WIRE (RED) 140L	1	
* 37	332-083	BATTERY BCC 1812 (EUROPE, AUS, NZL)	2	
* 37	332-583	BATTERY BCC 1812 (USA)	2	

STANDARD ACCESSORIES

ITEM NO.	CODE NO.	DESCRIPTION	NO. USED	REMARKS
501		CHARGER (MODEL UC 18YK)	1	
502	983-006	+ DRIVER BIT NO. 2 65L	1	
503	332-022	CASE (BLACK)	1	