

HITACHI

LIST NO. F869

ELECTRIC TOOL PARTS LIST

■ CORDLESS DRIVER DRILL Model DS 14DVF

2002-2-20
(E1)

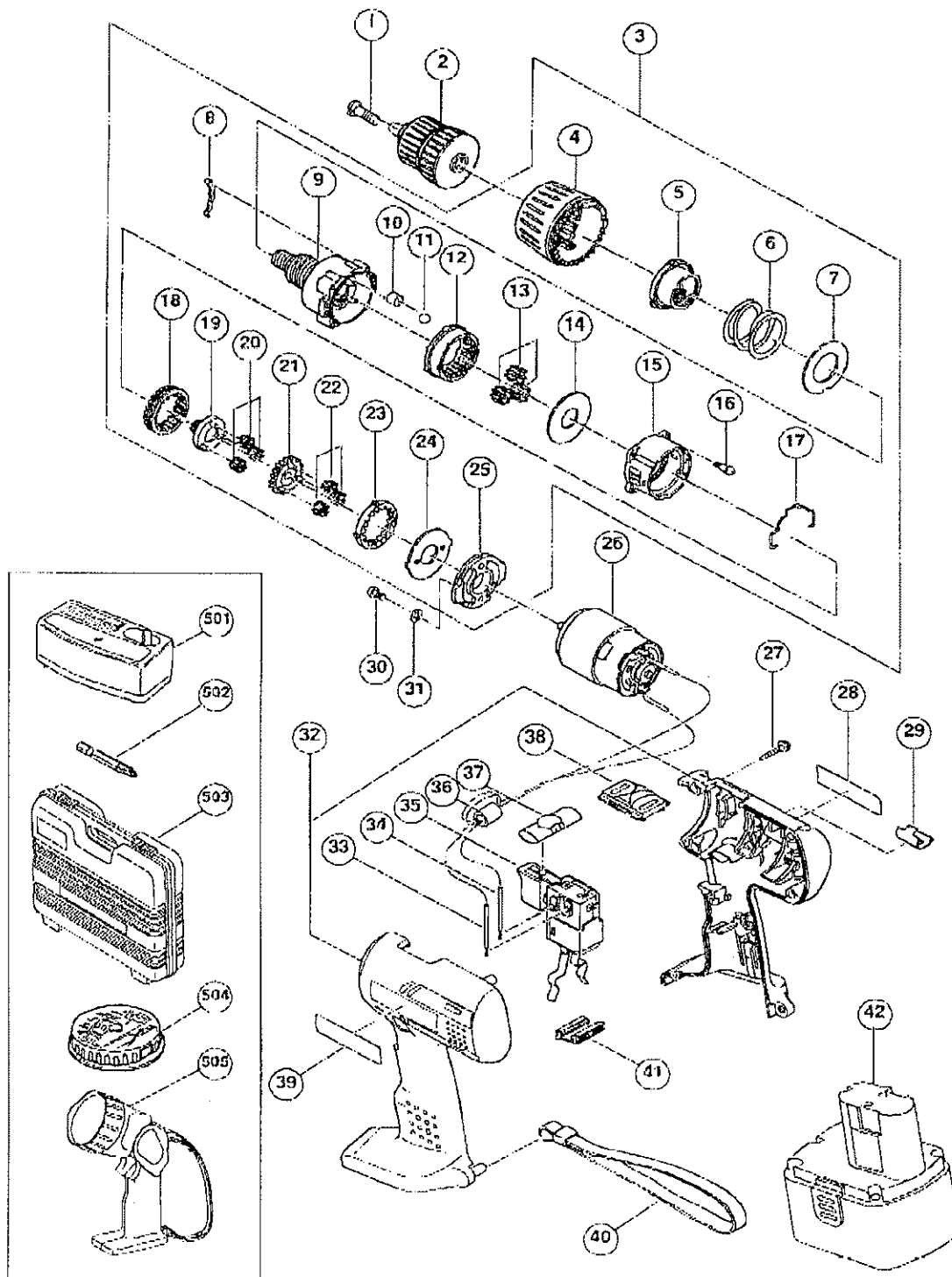

PARTS

DS 14DVF

ITEM NO.	CODE NO.	DESCRIPTION	NO. USED	REMARKS
1	318-228	SPECIAL SCREW (LEFT HAND) M5X35	1	
2	312-516	DRILL CHUCK 10TLRD-N (W/O CHUCK WRENCH)	1	
3	320-660	GEAR BOX ASS'Y	1	INCLUD.4-25
4	320-661	CAP	1	
5	318-232	NUT	1	
6	312-709	SPRING	1	
7	312-714	WASHER (D)	1	
8	312-713	CLICK SPRING	1	
9	318-230	FRONT CASE	1	
10	319-744	ROLLER	6	
11	306-936	STEEL BALL D5	6	
12	312-715	RING GEAR	1	
13	312-705	PLANET GEAR (C) SET (3 PCS.)	3	
14	312-704	WASHER (A)	1	
15	312-697	REAR CASE	1	
16	315-817	SCREW SET D3X12 (6 PCS.)	4	
17	311-962	SHIFT ARM	1	
18	315-137	SLIDE RING GEAR	1	
19	315-805	PINION (C)	1	
20	315-816	PLANET GEAR (B) SET (3 PCS.)	3	
21	315-804	PINION (B)	1	
22	315-815	PLANET GEAR (A) SET (3 PCS.)	3	
23	315-136	FIRST RING GEAR	1	
24	312-716	WASHER (B)	1	
25	318-231	MOTOR SPACER	1	
26	320-648	MOTOR	1	
27	991-672	TAPPING SCREW (W/WASHER) D3X16	8	
28		NAME PLATE	1	
29	318-237	BIT HOLDER	1	
30	949-203	MACHINE SCREW M3X8 (10 PCS.)	2	
31	949-451	SPRING WASHER M3 (10 PCS.)	2	
32	320-647	HOUSING (A),(B) SET	1	
33	320-850	INTERNAL WIRE (BLACK)	1	
33	306-041	INTERNAL WIRE (B) (BLACK)	1	FOR NZL,AUS,USA,CAN
34	320-649	INTERNAL WIRE (RED)	1	
34	306-040	INTERNAL WIRE (B) (RED)	1	FOR NZL,AUS,USA,CAN
35	320-145	DC-SPEED CONTROL SWITCH	1	
36	318-247	FERRITE CORE	1	FOR GBR,FRG,NOR,SWE,DEN
37	319-760	PUSHING BUTTON	1	
38	318-234	SHIFT KNOB	1	
39		HITACHI LABEL	1	
40	306-952	STRAP (BLACK)	1	
41	315-141	TERMINAL SUPPORT (A)	1	
42	319-933	BATTERY EB 1414 (W/ENGLISH N.P.)	1	
42	320-609	BATTERY EB 1414 (W/ENGLISH N.P.)	1	FOR NZL
42	320-610	BATTERY EB 1414 (W/ENGLISH N.P.)	1	FOR USA,CAN

