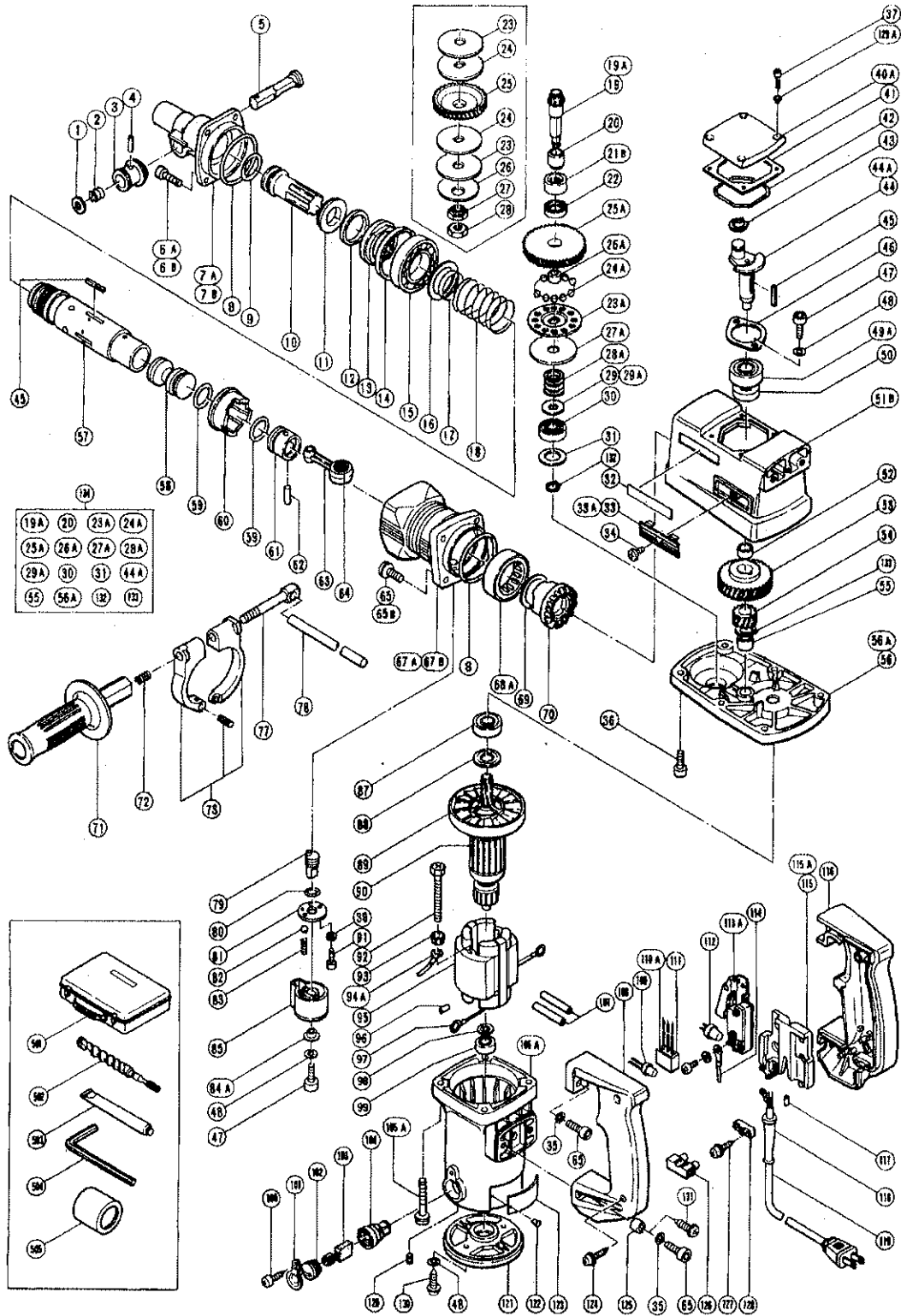

# ELECTRIC TOOL PARTS LIST

**■ HAMMER DRILL**

1989·7·6

**Model DH38YA**
**DH38YA(E3)**

## PARTS

DH 38YA

ITEM NO.	CODE NO.	DESCRIPTION	NO. USED	REMARKS
1	983-242	STOP WASHER	1	
2	981-937	STOPPER SPRING	1	
3	983-241	KNOB (A)	1	
4	943-364	NEEDLE ROLLER D4X20	1	
5	985-372	STOP LEVER	1	
6A	981-942	SEAL LOCK HEX. SOCKET HD. BOLT M6X25	4	TILL 6.1984
6B	991-896	SEAL LOCK BOLT M7X25	4	SINCE 8.1984
7A	985-371	FRONT COVER	1	TILL 6.1984
7B	985-367	FRONT COVER	1	SINCE 8.1984
8	956-996	O-RING (1A5-60)	1	
9	981-857	O-RING (C)	1	
10	985-370	SECOND HAMMER	1	
11	981-862	DAMPER WASHER	1	
12	981-861	DAMPER	1	
13	981-860	CYLINDER CAP	1	
14	981-859	URETHANE RING	1	
15	600-7DD	BALL BEARING 6007DDUAV2S	1	
16	981-973	CYLINDER WASHER	1	
17	981-858	VALVE BAND	1	
18	981-957	SPRING (A)	1	
19	981-849	THIRD PINION	1	TILL 7.1988
19A	992-796	THIRD PINION	1	SINCE 8.1988
20	981-850	SLEEVE	1	
21B	981-852	NEEDLE BEARING (A) (HK2012)	1	
22	981-851	OIL SEAL (B)	1	
23	956-207	SLIP PLATE (B)	2	TILL 7.1988
23A	992-792	HOLDER	1	SINCE 8.1988
24	981-941	CLUTCH PLATE	2	TILL 7.1988
24A	959-150	STEEL BALL D6.35 (10 PCS.)	12	SINCE 8.1988
25	981-848	SECOND GEAR	1	TILL 7.1988
25A	992-795	SECOND GEAR	1	SINCE 8.1988
26	944-514	BELLEVILLE SPRING	1	TILL 7.1988
26A	992-806	METAL	1	SINCE 8.1988
27	981-884	SPECIAL NUT (B)	1	TILL 7.1988
27A	992-793	PLATE	1	SINCE 8.1988
28	981-883	SPECIAL NUT (A)	1	TILL 7.1988
28A	992-794	SPRING	1	SINCE 8.1988
29	944-516	BEARING WASHER (B)	1	TILL 7.1988
29A	992-791	WASHER	1	SINCE 8.1988
30	629-VVM	BALL BEARING 629VVMC2EPS2L	1	
31	944-525	BEARING WASHER (C)	1	
32	957-561	HITACHI LABEL	1	
33	980-735	WIND GUIDE	2	TILL 7.1987
33A	991-713	WIND GUIDE (B)	2	SINCE 8.1987
34	949-322	FLAT HD. SCREW M4X10 (10 PCS.)	2	TILL 7.1987
35	949-455	SPRING WASHER M6 (10 PCS.)	4	TILL 2.1987
36	949-660	HEX. SOCKET HD. BOLT M6X20 (10 PCS.)	2	
37	983-162	SEAL LOCK HEX. SOCKET HD. BOLT M4X12	4	
38	949-453	SPRING WASHER M4 (10 PCS.)	2	
40A	991-718	CRANK COVER	1	
41	980-749	SEAL PACKING	1	
42	980-744	O-RING (S-55)	1	

## PARTS

DH 38YA

ITEM NO.	CODE NO.	DESCRIPTION	NO. USED	REMARKS
43	939-542	RETAINING RING FOR D12 SHAFT (10 PCS.)	1	
44	981-844	CRANK SHAFT	1	TILL 7.1988
44A	991-954	CRANK SHAFT	1	SINCE 8.1988
45	971-750	FEATHER KEY 3X3X20	5	
46	981-847	BEARING COVER	1	
47	984-509	SEAL LOCK HEX. SOCKET HD. BOLT M6X14	5	TILL 2.1987,2PCS. FOR TAIL COVER
48	949-454	SPRING WASHER M6 (10 PCS.)	6	
49A	620-3DD	BALL BEARING 6203DDCMV2S	1	
50	971-745	OIL SEAL (A)	1	
51B	991-768	CRANK CASE ASSY	1	INCLUD.21,22,33A
52	980-706	COLLAR	1	
53	981-845	FIRST GEAR	1	
54	981-846	SECOND PINION	1	
55	939-299	NEEDLE BEARING (M661)	1	
56	981-952	GEAR COVER	1	TILL 7.1988
56A	991-953	GEAR COVER	1	SINCE 8.1988
57	981-969	CYLINDER	1	
58	981-855	STRIKER	1	
59	980-710	O-RING	2	
60	981-956	CLUTCH	1	
61	981-885	PISTON	1	
62	980-708	PISTON PIN	1	
63	980-707	CONNECTING ROD ASSY	1	INCLUD.64
64	980-756	NEEDLE BEARING (NSK AJ50 1203)	1	
65	949-652	HEX. SOCKET HD. BOLT M6X25 (10 PCS.)	8	TILL 11.1984
65	949-652	HEX. SOCKET HD. BOLT M6X25 (10 PCS.)	4	SINCE 12.1984(SINCE 12.1984 TILL 2.1987,2PCS. FOR HANDLE)
65B	991-712	HEX. SOCKET HD. BOLT (W/FLANGE) M6X25	4	SINCE 12.1984
67A	982-424	CYLINDER CASE	1	TILL 5.1984
67B	991-764	CYLINDER CASE	1	SINCE 6.1984
68A	993-069	NEEDLE BEARING (M455520)	1	
69	981-955	THRUST WASHER	1	
70	981-954	THIRD GEAR	1	
71	981-870	SIDE HANDLE	1	
72	672-612	SPRING	1	
73	981-960	HANDLE HOLDER	1	
77	971-785	HANDLE BOLT	1	
78	971-786	STOPPER ROD	1	
79	981-964	LEVER SHAFT	1	
80	981-967	O-RING (A)	1	
81	981-965	SHAFT COVER	1	
82	959-155	STEEL BALL D3.97 (10 PCS.)	1	
83	981-966	SPRING (B)	1	
84A	991-711	DISTANCE PIECE (B)	1	
85	981-963	LEVER	1	
87	620-2VV	BALL BEARING 6202VVCMP2S	1	
88	980-700	DUST WASHER (B)	1	
89	980-740	FAN	1	
* 90	981-971C	(ARMATURE ASSY 110V-115V)	1	INCLUD.89 FOR USA,CAN
* 90	981-971E	ARMATURE ASSY 220V-230V	1	INCLUD.89 FOR NZL
* 90	981-971F	ARMATURE ASSY 240V	1	INCLUD.89 FOR AUS
91	949-813	HEX. SOCKET HD. BOLT M4X12 (10 PCS.)	2	
92	980-251	HEX. HD. TAPPING SCREW D5X65	2	

## PARTS

DH 38YA

ITEM NO.	CODE NO.	DESCRIPTION	NO. USED	REMARKS	
	93	956-764	SPECIAL WASHER	2	
*	94A	986-277	INTERNAL WIRE	1	FOR NZL
*	95	981-970C	STATOR ASS'Y 110V-115V	1	INCLUD.96,97 FOR USA,CAN
*	95	981-970G	STATOR ASS'Y 220V-230V	1	INCLUD.96,97 FOR NZL
*	95	981-970H	STATOR ASS'Y 240V	1	INCLUD.96,97 FOR AUS
	96	981-373	TUBE (D)	2	
	97	930-703	BRUSH TERMINAL	2	
	98	980-698	DUST WASHER (A)	1	
	99	608-VVM	BALL BEARING 608VVMC2EPS2L	1	
	100	958-715	TAPPING SCREW D4X10	2	
	101	981-959	CAP COVER	2	
	102	981-781	BRUSH CAP	2	
	103	981-812Z	CARBON BRUSH (AUTO STOP TYPE) (1 PAIR)	2	
	104	981-586	BRUSH HOLDER	2	
	105A	982-411	HEX. SOCKET HD. BOLT (W/FLANGE) M6X50	4	
*	106A	991-787	HOUSING ASSY (B)	1	INCLUD.104,120,130,131
*	106A	985-399	HOUSING ASSY (B)	1	INCLUD.104,120,130,131 FOR U-HOLE
	107		VINYL TUBE (ID7XT0.5X120)	1	
	108	981-867	HANDLE (B)	1	
*	109	959-140	CONNECTOR 50091 (10 PCS.)	1	FOR NZL,CAN
*	110A	994-273	NOISE SUPPRESSOR	1	FOR NZL
*	111	930-153	SUPPORT (B)	1	FOR NZL
*	112	959-141	CONNECTOR 50092 (10 PCS.)	1	FOR NZL
*	113A	981-533Z	SWITCH (2P PILLAR TYPE) W/O LOCK	1	FOR AUS
*	113A	992-891	SWITCH (A) (1P SCREW TYPE) W/O LOCK	1	
*	114	981-974Z	INTERNAL WIRE	1	FOR NZL
*	115	981-869	SUPPORT	1	TILL 7.1988
*	115	981-986Z	SUPPORT (A)	1	FOR AUS
*	115A	990-082	SUPPORT (E)	1	SINCE 8.1988
	116	981-868	HANDLE (A)	1	
*	117	981-373	TUBE (D)	2	FOR AUS
	118	940-778	CORD ARMOR D10.7	1	
*	119	500-249Z	CORD	1	(CORD ARMOR D10.7) FOR USA,CAN
*	119	500-227Z	CORD	1	(CORD ARMOR D10.7) FOR NZL
*	119	500-408Z	CORD	1	(CORD ARMOR D10.7) FOR AUS
	120	938-477	HEX. SOCKET SET SCREW M5X8	2	
	121	981-951	TAIL COVER	1	
	122	940-510	RIVET D2.5X4.8 (10 PCS.)	2	
	123		NAME PLATE	1	
	124	956-636	TAPPING SCREW (W/WASHER) D4X25	2	
	125	981-868	COLLAR	4	
*	126	938-307Z	PILLAR TERMINAL	1	FOR USA
	127	984-750	TAPPING SCREW (W/FLANGE) D4X16	2	
	128	980-266	CORD CLIP	1	
	129A	990-148	DISTANCE PIECE (A)	4	TILL 1.1988
	130	985-480	TAPPING SCREW (W/WASHER) D5X20	2	SINCE 3.1987
	131	992-802	TAPPING SCREW D6X25	2	SINCE 3.1987
	132	992-805	RETAINING RING FOR D9 SHAFT	1	SINCE 8.1988
	133	987-261	RETAINING RING FOR D17 SHAFT	1	SINCE 8.1988
	134	985-490	SLIP CLUTCH ASS'Y	1	INCLUD.19A,20,23A-29A,30,31,44A,55,56A,132,133

\* : ALTERNATIVE PARTS

07-89