

ELECTRIC TOOL PARTS LIST

■HAMMAER DRILL
Model DH 24VD

1994 · 3 · 20
(E1)

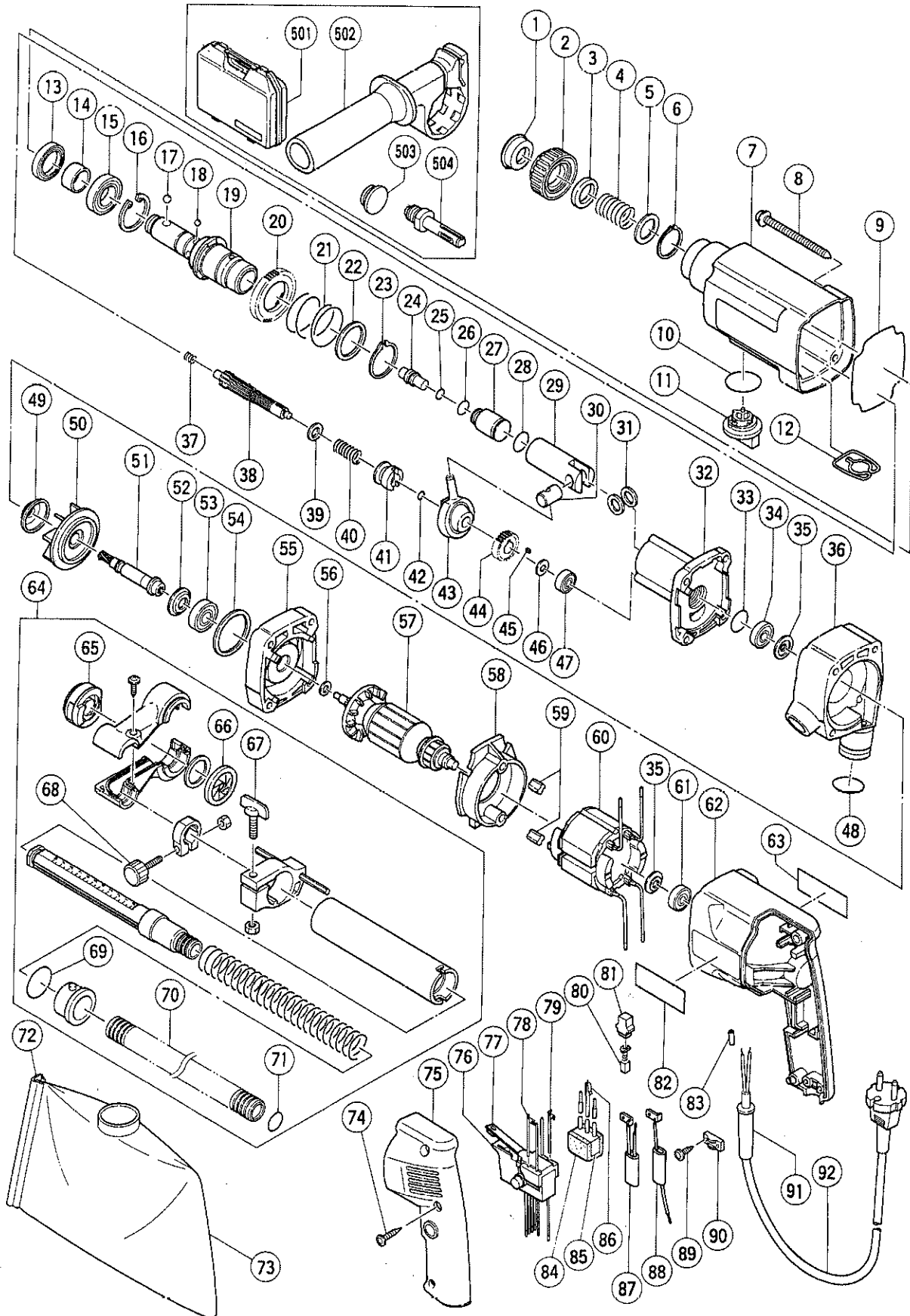

PARTS

DH 24VD

ITEM NO.	CODE NO.	DESCRIPTION	NO. USED	REMARKS
1	306-345	FRONT CAP	1	
2	306-992	GRIP	1	
3	306-343	BALL HOLDER	1	
4	306-342	HOLDER SPRING	1	
5	984-118	WASHER (B)	1	
6	939-547	RETAINING RING FOR D20 SHAFT (10 PCS.)	1	
7	307-689	GEAR COVER	1	
8	302-210	TAPPING SCREW (W/FLANGE) D5X90	4	
9	301-657	RUBBER SEAL	1	
10	301-684	O - RING (S - 30)	1	
11	301-651	CHANGE LEVER	1	
12	301-685	SPRING (C)	1	
13	307-688	OIL SEAL	1	
14	307-690	SLEEVE	1	
15	690-4CM	BALL BEARING 6904CM	1	
16	986-147	RETAINING RING FOR D37 HOLE	1	
17	959-156	STEEL BALL D7.0 (10 PCS.)	2	
18	959-154	STEEL BALL D5.558 (10 PCS.)	4	
19	308-987	CYLINDER	1	
20	301-677	SECOND GEAR	1	
21	301-678	SPRING (A)	1	
22	301-679	WASHER (A)	1	
23	948-310	RETAINING RING FOR D30 SHAFT	1	
24	301-671	SECOND HAMMER	1	
25	301-672	O - RING (B)	1	
26	301-680	O - RING (FPM 810)	1	
27	301-669	STRIKER	1	
28	301-670	O - RING (A)	1	
29	301-668	PISTON	1	
30	301-666	PISTON PIN	1	
31	301-667	WASHER (C)	2	
32	301-656	INNER COVER	1	
33	876-796	O - RING (P - 22)	1	
34	608-DDM	BALL BEARING 608DDMC2EPS2S	1	
35	982-631	WASHER (A)	2	
36	302-110	CASING (B)	1	
37	301-664	SPRING (B)	1	
38	301-658	SECOND SHAFT	1	
39	301-659	WASHER (B)	1	
40	301-660	CLUTCH SPRING	1	
41	301-661	CLUTCH	1	
42	992-912	O - RING (S - 8)	1	
43	306-990	RECIPROCATING BEARING	1	
44	301-665	FIRST GEAR	1	
45	944-109	FEATHER KEY 3X3X8	1	
46	301-663	SPACER	1	
47	626-VVM	BALL BEARING 626VVMC2ERPS2S	1	
48	302-371	O - RING	1	
49	302-113	SEAL PLATE	1	
50	302-111	DUST FAN	1	
51	302-112	DUST SHAFT	1	

*: ALTERNATIVE PARTS

PARTS

DH 24VD

ITEM NO.	CODE NO.	DESCRIPTION	NO. USED	REMARKS	
52	993-052	DUST WASHER	1		
53	600-1DD	BALL BEARING 8001DDUCMPS2S	1		
54	302-372	FELT	1		
55	302-109	CASING (A)	1		
56	302-114	RUBBER SLEEVE	1		
*	57	360-161C	ARMATURE 110V - 115V	1	
*	57	360-161D	ARMATURE 120V - 127V	1	
*	57	360-161E	ARMATURE 220V	1	
*	57	360-161F	ARMATURE 230V - 240V	1	
58	301-655	FAN GUIDE ASS'Y	1	INCLUD.59	
59	994-343	RUBBER BUSHING	2		
*	60	340-188C	STATOR (C) 110V - 115V	1	
*	60	340-188D	STATOR (C) 120V - 127V	1	
*	60	340-188G	STATOR (C) 220V - 230V	1	
*	60	340-188H	STATOR (C) 230V - 240V	1	FOR SIN,KUW,NGU,NZL,AUS,GBR (240V),SAF
61	608-VVM	BALL BEARING 608VVMC2EPS2L	1		
62	302-051	HOUSING	1		
*	63	NAME PLATE	1		
64	302-074	DUST COLLECTION ADAPTER ASS'Y	1	INCLUD.65 - 70	
65	302-077	NOZZLE SEAL	1		
66	302-075	RUBBER CAP	1		
67	301-801	WING BOLT M6X27	1		
68	303-159	KNOB BOLT M4X25.5	1		
69	872-470	O - RING (S - 26)	1		
70	302-076	HOSE ASS'Y	1	INCLUD.71	
71	873-095	O - RING (P - 16)	1		
72	302-386	RAIL	1		
73	302-048	DUST BAG ASS'Y	1	INCLUD.72	
74	301-653	TAPPING SCREW (W/FLANGE) D4X20 (BLACK)	3		
75	302-052	HANDLE COVER	1		
*	76	302-053	SPEED CONTROL SWITCH ASS'Y (2P)220V - 240V	1	INCLUD.77
*	76	301-690	SPEED CONTROL SWITCH ASS'Y (2P)110V - 127V	1	INCLUD.77
77	303-781	REVERSING SWITCH	1		
78	301-688	INTERNAL WIRE (B) (BLUE)	1		
79	301-689	INTERNAL WIRE (B) (BROWN)	1		
80	999-080	CARBON BRUSH (AUTO STOP TYPE) (1 PAIR)	2		
81	955-203	BRUSH HOLDER	2		
82		HITACHI LABEL	1		
*	83	981-373	TUBE (D)	2	FOR CORD
*	84	930-153	SUPPORT (B)	1	FOR ITA,DEN
*	85	994-273	NOISE SUPPRESSOR	1	FOR ITA,DEN,SUI
*	86	302-488	EARTH TERMINAL	1	FOR NOISE SUPPRESSOR
*	87	302-054	CHOKE COIL (A)	1	FOR NZL,GBR,SAF,ITA,FRG,FRA,BEL,HOL,DEN, FIN,SWE,AUT,NOR,SUI
*	88	302-056	CHOKE COIL (B)	1	FOR NZL,GBR,SAF,ITA,FRG,FRA,BEL,HOL,DEN, FIN,SWE,AUT,NOR,SUI
89	984-750	TAPPING SCREW (W/FLANGE) D4X16	2		
90	937-631	CORD CLIP	1		
*	91	980-193	CORD ARMOR D10.2	1	
*	91	930-487	CORD ARMOR D8.2	1	
*	92	500-201Z	CORD	1	(CORD ARMOR D10.2)

*: ALTERNATIVE PARTS

STANDARD ACCESSORIES

DH 24VD

ITEM NO.	CODE NO.	DESCRIPTION	NO. USED	REMARKS
501	302-211	CASE	1	
502	307-894	SIDE HANDLE	1	
503	302-374	CAP	1	
* 504	303-624	CHUCK ADAPTER (D) (SDS PLUS)	1	FOR AUS

OPTIONAL ACCESSORIES

ITEM NO.	CODE NO.	DESCRIPTION	NO. USED	REMARKS
601	306-369	DRILL BIT (SLENDER SHAFT) D3.4X90	1	
602	306-368	DRILL BIT (SLENDER SHAFT) D3.5X90	1	
603	306-370	ADAPTER FOR SLENDER SHAFT (SDS PLUS)	1	
604	944-460	TAPER SHANK DRILL BIT D11X100	1	
605	944-461	TAPER SHANK DRILL BIT D12.3X110	1	
606	993-038	TAPER SHANK DRILL BIT D12.7X110	1	
607	944-462	TAPER SHANK DRILL BIT D14.3X110	1	
608	944-500	TAPER SHANK DRILL BIT D14.5X110	1	
609	944-463	TAPER SHANK DRILL BIT D17.5X120	1	
610	944-464	TAPER SHANK DRILL BIT D21.5X140	1	
611	303-617	TAPER SHANK ADAPTER (SDS PLUS) NO.1	1	
612	303-618	TAPER SHANK ADAPTER (SDS PLUS) NO.2	1	
613	303-619	A – TAPER SHANK ADAPTER (SDS PLUS)	1	
614	303-620	B – TAPER SHANK ADAPTER (SDS PLUS)	1	
615	944-477	COTTER	1	
616	303-332	HAMMER DRILL CHUCK SET 13MM	1	INCLUD.617,618
617	303-334	CHUCK HANDLE	1	
618	303-335	RUBBER CAP	1	
619	302-976	ANCHOR SETTING ADAPTER A (SDS+)W1/4X260L	1	
620	302-975	ANCHOR SETTING ADAPTER A(SDS+)W5/16X260L	1	
621	303-621	ANCHOR SETTING ADAPTER A (SDS+)W3/8X180L	1	
622	302-974	ANCHOR SETTING ADAPTER A (SDS+)W3/8X260L	1	
623	302-979	ANCHOR SETTING ADAPTER B (SDS+)W1/4X260L	1	
624	302-978	ANCHOR SETTING ADAPTER B(SDS+)W5/16X260L	1	
625	303-622	ANCHOR SETTING ADAPTER B (SDS+)W3/8X180L	1	
626	302-977	ANCHOR SETTING ADAPTER B (SDS+)W3/8X260L	1	
627	971-794	ANCHOR SETTING ADAPTER A W1/4" (MANUAL)	1	
628	971-795	ANCHOR SETTING ADAPTER A W5/16" (MANUAL)	1	
629	971-796	ANCHOR SETTING ADAPTER A W3/8" (MANUAL)	1	
630	971-797	ANCHOR SETTING ADAPTER A W1/2" (MANUAL)	1	
631	971-798	ANCHOR SETTING ADAPTER A W5/8" (MANUAL)	1	
632	971-799	ANCHOR SETTING ADAPTER B W1/4" (MANUAL)	1	
633	971-800	ANCHOR SETTING ADAPTER B W5/16" (MANUAL)	1	
634	971-801	ANCHOR SETTING ADAPTER B W3/8" (MANUAL)	1	
635	971-802	ANCHOR SETTING ADAPTER B W1/2" (MANUAL)	1	
636	971-803	ANCHOR SETTING ADAPTER B W5/8" (MANUAL)	1	

* : ALTERNATIVE PARTS

OPTIONAL ACCESSORIES

DH 24VD

ITEM NO.	CODE NO.	DESCRIPTION	NO. USED	REMARKS
637	982-684	CENTER PIN (A)	1	
638	982-685	CENTER PIN (B)	1	
639	982-672	CORE BIT (A) 25MM	1	
640	982-673	CORE BIT (A) 29MM	1	
641	982-674	CORE BIT (A) 32MM	1	INCLUD.642
642	982-686	GUIDE PLATE (FOR CORE BIT 32MM)	1	
643	982-675	CORE BIT (A) 35MM	1	INCLUD.644
644	982-687	GUIDE PLATE (FOR CORE BIT 35MM)	1	
645	982-676	CORE BIT (A) 38MM	1	INCLUD.646
646	982-688	GUIDE PLATE (FOR CORE BIT 38MM)	1	
647	982-677	CORE BIT (B) 45MM	1	INCLUD.648
648	982-689	GUIDE PLATE (FOR CORE BIT 45MM)	1	
649	982-678	CORE BIT (B) 50MM	1	INCLUD.650
650	982-690	GUIDE PLATE (FOR CORE BIT 50MM)	1	
651	303-625	CORE BIT SHANK (SDS PLUS) 25 - 38MM 105L	1	
652	303-626	CORE BIT SHANK (SDS PLUS) 25 - 38MM 300L	1	
653	303-627	CORE BIT SHANK (SDS PLUS) 45 - 90MM 300L	1	
654	303-046	BULL POINT (SDS+) 250MM(ROUND SHANK TYPE)	1	
655	303-044	CHEMICAL ANCHOR ADAPTER (SDS+)12.7MMX90L	1	
656	303-045	CHEMICAL ANCHOR ADAPTER(SDS+)19.0MMX100L	1	
657	303-820	DRILL CHUCK AND ADAPTER SET (SDS PLUS)	1	INCLUD.658,661
658	950-275	DRILL CHUCK 13VLR	1	INCLUD.659,660
659	930-515	CHUCK WRENCH 10G	1	
660	981-122	SPECIAL SCREW M6X22	1	
661	303-623	CHUCK ADAPTER (G) (SDS PLUS)	1	
662	950-272	DRILL CHUCK 13VLA	1	INCLUD.659
663	303-624	CHUCK ADAPTER (D) (SDS PLUS)	1	
664	971-511Z	+ DRIVER BIT (A) NO.2 25L	1	
665	971-512Z	+ DRIVER BIT (A) NO.3 25L	1	
666	971-787	DUST CUP	1	
667	306-885	DUST COLLECTOR (B) ASS'Y	1	INCLUD.668
668	306-910	SOCKET ADAPTOR (B)	1	
669	302-741	PAPER DUST BAG (10 PCS.)	1	
670	980-927	GREASE FOR HAMMER.HAMMER DRILL (500G)	1	
671	308-471	GREASE FOR HAMMER.HAMMER DRILL (70G)	1	
672	981-840	GREASE (A) FOR HAMMER.HAMMER DRILL (30G)	1	
673	306-927	SILICON RUBBER	1	

* : ALTERNATIVE PARTS