

ELECTRIC TOOL PARTS LIST

CORDLESS ROTARY HAMMER 2004 • 6 • 10
Model DH 24DV (E1)

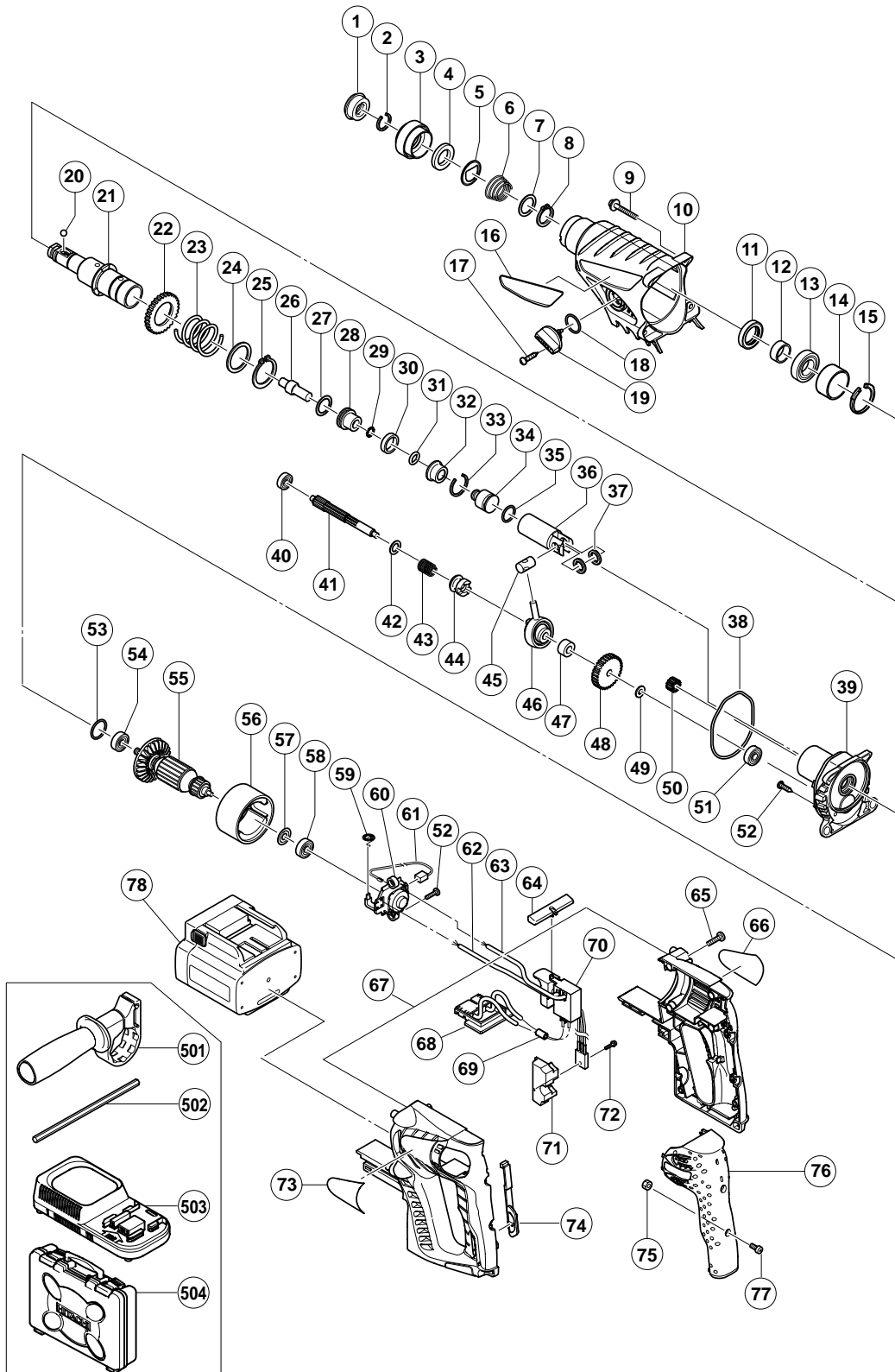

PARTS

DH 24DV

ITEM NO.	CODE NO.	DESCRIPTION	NO. USED	REMARKS
1	306-345	FRONT CAP	1	
2	306-340	STOPPER RING	1	
3	323-154	GRIP	1	
4	322-810	BALL HOLDER	1	
5	322-811	HOLDER PLATE	1	
6	322-812	HOLDER SPRING	1	
7	984-118	WASHER (B)	1	
8	939-547	RETAINING RING FOR D20 SHAFT (10 PCS.)	1	
9	305-558	TAPPING SCREW (W/FLANGE) D5X25 (BLACK)	4	
10	323-167	GEAR COVER	1	
11	307-688	OIL SEAL	1	
12	322-815	SLEEVE	1	
13	690-4DD	BALL BEARING 6904DDPS2L	1	
14	322-819	SLEEVE (A)	1	
15	322-813	RETAINING RING 37MM	1	
16	323-172	HITACHI PLATE (GREEN)	1	
17	323-239	TAPPING SCREW D2.6	1	
18	878-885	O-RING (S-18)	1	
19	323-161	CHANGE LEVER	1	
20	959-156	STEEL BALL D7.0 (10 PCS.)	1	
21	322-814	CYLINDER	1	
22	301-677	SECOND GEAR	1	
23	316-135	SPRING (A)	1	
24	301-679	WASHER (A)	1	
25	948-310	RETAINING RING FOR D30 SHAFT	1	
26	322-803	SECOND HAMMER	1	
27	944-486	O-RING (1AP-20)	1	
28	322-804	HAMMER HOLDER	1	
29	322-802	O-RING (B)	1	
30	322-805	DAMPER (A)	1	
31	322-808	O-RING (C)	1	
32	322-806	DAMPER HOLDER	1	
33	322-807	STOPPER RING	1	
34	322-801	STRIKER	1	
35	322-834	O-RING (I.D. 16)	1	
36	322-800	PISTON	1	
37	322-799	WASHER (C)	2	
38	323-150	RUBBER SEAL	1	
39	323-157	INNER COVER ASS'Y	1	INCLUD. 51
40	626-VVM	BALL BEARING 626VVC2PS2L	1	
41	323-151	SECOND SHAFT	1	
42	301-659	WASHER (B)	1	
43	301-660	CLUTCH SPRING	1	
44	301-661	CLUTCH	1	
45	322-798	PISTON PIN	1	
46	306-990	RECIPROCATING BEARING	1	
47	323-152	COLLAR	1	
48	323-153	FIRST GEAR	1	
49	301-663	SPACER	1	
50	323-170	PINION	1	
51	626-VVM	BALL BEARING 626VVC2PS2L	1	

