

ELECTRIC TOOL PARTS LIST

■HAMMER DRILL
Model DH 22VB

1997・4・15
(E4)

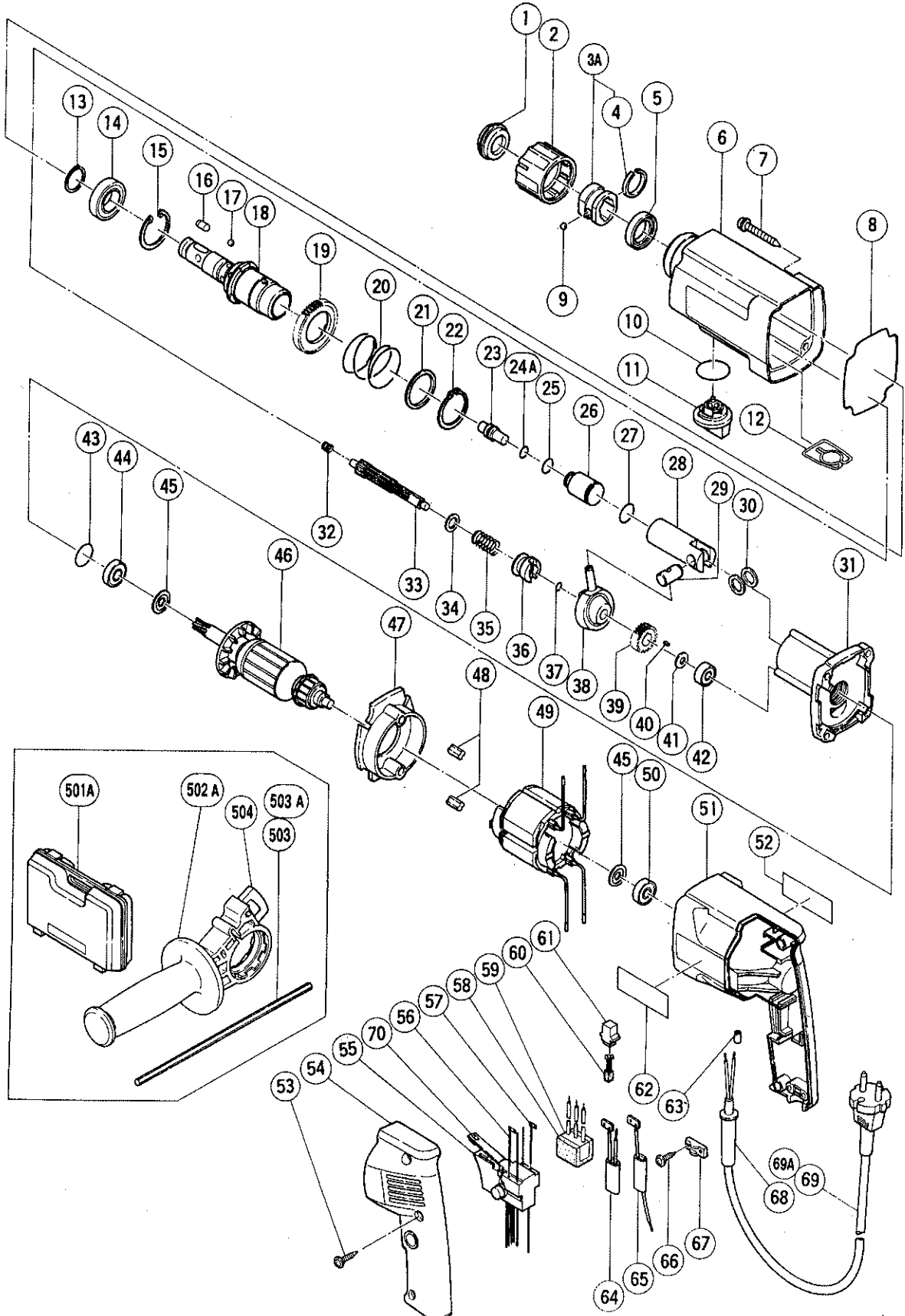

PARTS

DH 22VB

ITEM NO.	CODE NO.	DESCRIPTION	NO. USED	REMARKS
1	301-681	FRONT CAP	1	
2	302-049	GRIP	1	
3A	311-793	NEEDLE HOLDER ASS'Y	1	INCLUD.4
4	301-675	C - TYPE SPRING	1	
5	301-683	OIL SEAL	1	
6	302-078	GEAR COVER	1	
7	301-654	TAPPING SCREW (W/FLANGE) D5X35	4	
8	301-657	RUBBER SEAL	1	
9	959-150	STEEL BALL D6.35 (10 PCS.)	1	
10	301-684	O - RING (S - 30)	1	
11	302-050	CHANGE LEVER	1	
12	301-685	SPRING (C)	1	
13	939-547	RETAINING RING FOR D20 SHAFT (10 PCS.)	1	
14	690-4CM	BALL BEARING 6904CM	1	
15	986-147	RETAINING RING FOR D37 HOLE	1	
16	301-673	NEEDLE ROLLER	2	
17	959-154	STEEL BALL D5.556 (10 PCS.)	4	
18	301-676	CYLINDER	1	
19	301-677	SECOND GEAR	1	
20	301-678	SPRING (A)	1	
21	301-679	WASHER (A)	1	
22	948-310	RETAINING RING FOR D30 SHAFT	1	
23	301-671	SECOND HAMMER	1	
24A	301-672	O - RING (B)	1	
25	301-680	O - RING (FPM 810)	1	
26	301-669	STRIKER	1	
27	301-670	O - RING (A)	1	
28	301-668	PISTON	1	
29	301-666	PISTON PIN	1	
30	301-667	WASHER (C)	2	
31	301-656	INNER COVER	1	
32	301-664	SPRING (B)	1	
33	301-658	SECOND SHAFT	1	
34	301-659	WASHER (B)	1	
35	301-660	CLUTCH SPRING	1	
36	301-661	CLUTCH	1	
37	992-912	O - RING (S - 8)	1	
38	306-990	RECIPROCATING BEARING	1	
39	301-665	FIRST GEAR	1	
40	944-109	FEATHER KEY 3X3X8	1	
41	301-663	SPACER	1	
42	626-VVM	BALL BEARING 626VVMC2ERPS2S	1	
43	876-796	O - RING (P - 22)	1	
44	608-DDM	BALL BEARING 608DDMC2EPS2S	1	
45	982-631	WASHER (A)	2	
* 46	360-149C	ARMATURE 110V - 115V	1	
* 46	360-149D	ARMATURE 120V - 127V	1	
* 46	360-149E	ARMATURE 220V	1	
* 46	360-149F	ARMATURE 230V - 240V	1	
47	301-655	FAN GUIDE ASS'Y	1	INCLUD.48
48	994-343	RUBBER BUSHING	2	

*: ALTERNATIVE PARTS

PARTS

DH 22VB

ITEM NO.	CODE NO.	DESCRIPTION	NO. USED	REMARKS
* 49	340-188C	STATOR (C) 110V - 115V	1	
* 49	340-188D	STATOR (C) 120V - 127V	1	
* 49	340-188G	STATOR (C) 220V - 230V	1	
* 49	340-188H	STATOR (C) 230V - 240V	1	FOR SIN,KUW,NGU,NZL,AUS,SAF
50	608-VVM	BALL BEARING 608VVMC2EPS2L	1	
51	302-051	HOUSING	1	
52		NAME PLATE	1	
53	301-653	TAPPING SCREW (W/FLANGE) D4X20 (BLACK)	3	
54	302-052	HANDLE COVER	1	
* 55	301-690	SPEED CONTROL SWITCH ASS'Y (2P)100V - 127V	1	INCLUD.70
* 55	302-053	SPEED CONTROL SWITCH ASS'Y (2P)220V - 240V	1	INCLUD.70
* 56	301-688	INTERNAL WIRE (B) (BLUE)	1	
* 57	301-689	INTERNAL WIRE (B) (BROWN)	1	
* 58	930-153	SUPPORT (B)	1	FOR NOISE SUPPRESSOR
* 59	994-273	NOISE SUPPRESSOR	1	
60	999-080	CARBON BRUSH (AUTO STOP TYPE) (1 PAIR)	2	72
61	955-203	BRUSH HOLDER	2	
62		HITACHI LABEL	1	
* 63	981-373	TUBE (D)	2	FOR CORD
* 64	302-054	CHOKE COIL (A)	1	FOR NZL,GBR,SAF,ITA,FRG,FRA,BEL,HOL,DEN FIN,SWE,AUT,SUI,KOR
* 65	302-056	CHOKE COIL (B)	1	FOR NZL,GBR,SAF,ITA,FRG,FRA,BEL,HOL,DEN FIN,SWE,AUT,SUI,KOR
66	984-750	TAPPING SCREW (W/FLANGE) D4X16	2	
67	937-631	CORD CLIP	1	
* 68	980-193	CORD ARMOR D10.2	1	
* 68	930-487	CORD ARMOR D8.2	1	
* 69	500-239Z	CORD	1	(CORD ARMOR D10.2)
* 69	500-235Z	CORD	1	(CORD ARMOR D8.2)FOR INA,SUR
* 69	500-394Z	CORD	1	(CORD ARMOR D10.2)FOR SYR
* 69	500-406Z	CORD	1	(CORD ARMOR D8.2)FOR GBR,SAF
* 69	500-249Z	CORD	1	(CORD ARMOR D8.2)FOR USA,CAN
* 69	500-390Z	CORD	1	(CORD ARMOR D10.2)FOR ITA,FRG,FRA,HOL, DEN,FIN,SWE,AUT,NOR
* 69	500-391Z	CORD	1	(CORD ARMOR D10.2)FOR SUI
* 69	500-227Z	CORD	1	(CORD ARMOR D8.2)FOR NGU,NZL
* 69	500-408Z	CORD	1	(CORD ARMOR D10.2)FOR AUS
* 69	500-247Z	CORD	1	(CORD ARMOR D10.2) FOR CHN
* 69	500-409Z	CORD	1	(CORD ARMOR D8.2) FOR KOR
* 69A	500-424Z	CORD	1	(CORD ARMOR D8.2) FOR SIN,KUW
70	303-781	REVERSING SWITCH	1	

STANDARD ACCESSORIES

ITEM NO.	CODE NO.	DESCRIPTION	NO. USED	REMARKS
501A	301-691	CASE (DARK GREEN)	1	
502A	302-073	SIDE HANDLE	1	
* 503	310-331	DEPTH GAUGE	1	FOR USA
503	971-677	STOPPER	1	TILL 4.1991
503A	303-709	DEPTH GAUGE	1	SINCE 5.1991
504	303-158	KNOB BOLT N6X38	1	TILL 4.1991

*: ALTERNATIVE PARTS

