

## ENGINE TOOL PARTS LIST

### ENGINE HEDGE TRIMMER Model CH 62EA3

2010·2·26

(E1)

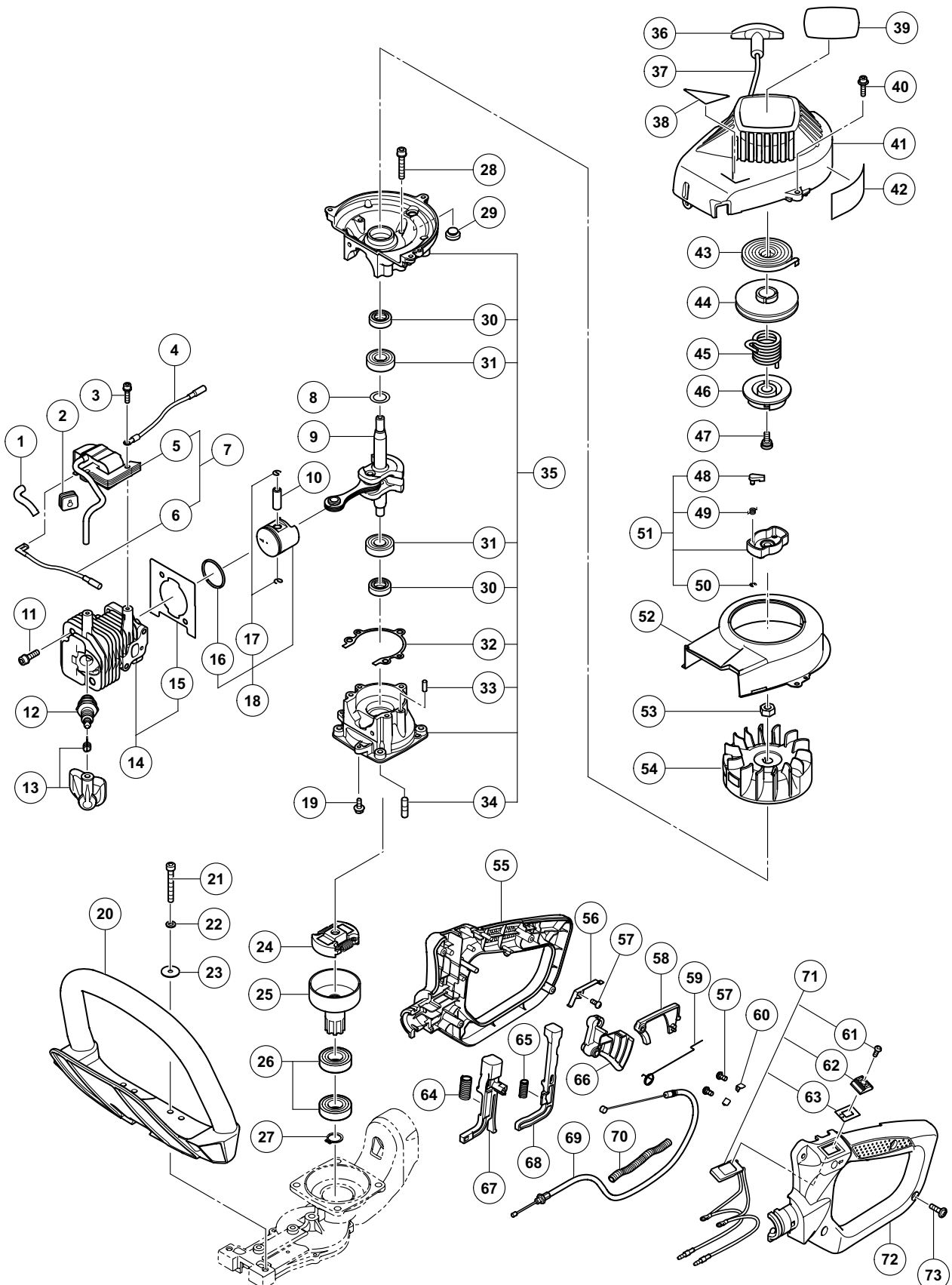

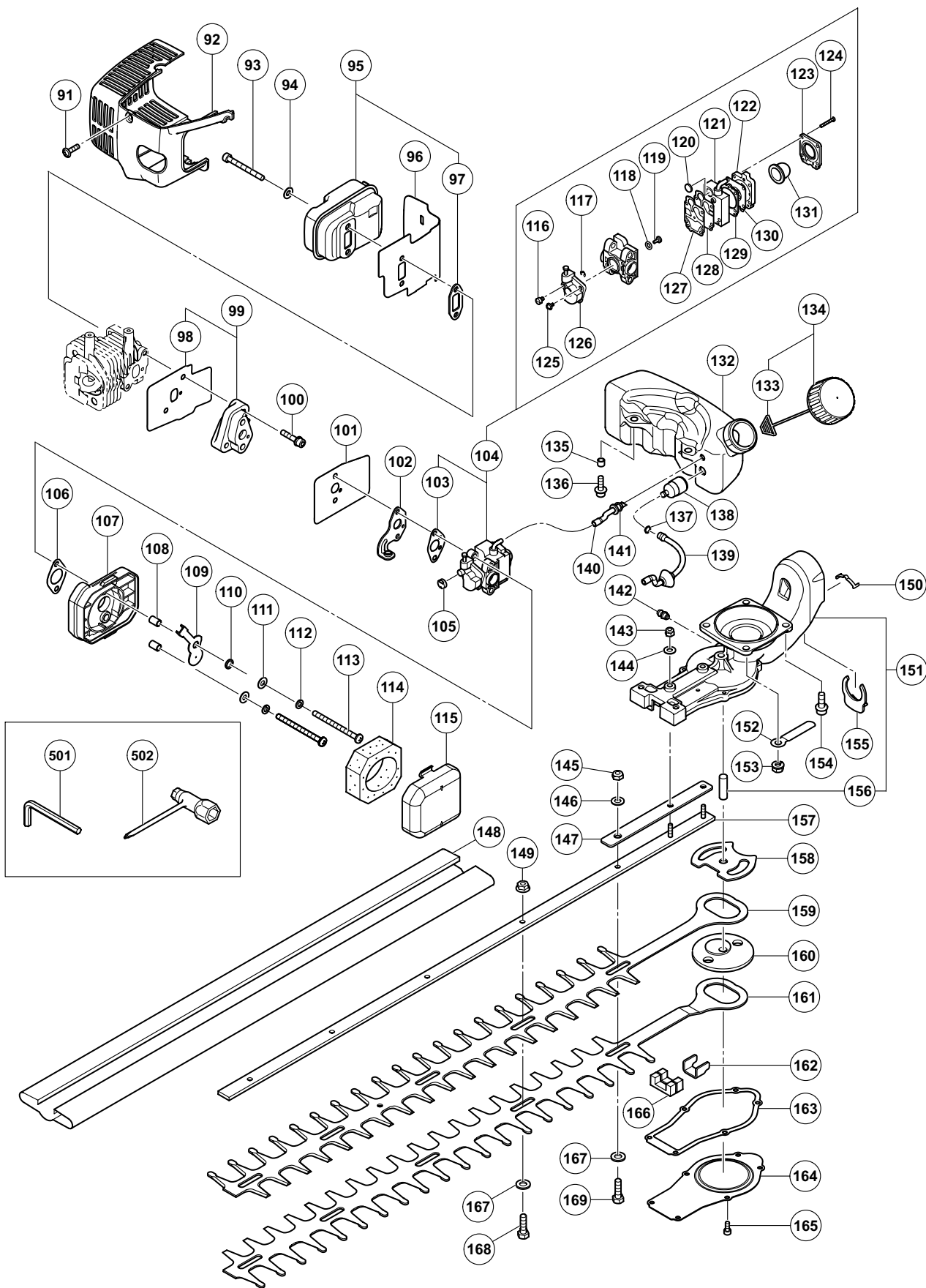

**PARTS**

CH 62EA3

ITEM NO.	CODE NO.	DESCRIPTION	NO. USED	REMARKS
1	668-4597	INSULATOR TUBE 50L	1	
2	668-8050	GROMMET	1	
3	668-4599	HEX. HOLE BOLT M4 X 18/WS	2	
4	668-8477	CORD	1	
5	668-7702	IGNITION COIL COMP.	1	
6	668-7918	CORD 200M	1	
7	668-7353	IGNITIONCOIL ASS'Y	1	INCLUD. 5, 6
* 8	668-4604	GEAR SHAFT SHIM 0.20	1	
* 8	668-4605	GEAR SHAFT SHIM 0.30	1	
9	668-6208	CRANK SHAFT COMP	1	
10	668-6015	PISTON PIN	1	
11	668-4586	HEX. HOLE BOLT M5 X 18/S	2	
12	668-5086	SPARK PLUG BPMR6A	1	
13	668-7476	SPARK PLUG CAP	1	
14	668-5480	CYLINDER ASS'Y	1	INCLUD. 15
15	668-5744	CYLINDER GASKET	1	
16	668-6118	PISTON RING	1	
17	668-4590	PISTON PIN CIRCLIP	2	
18	668-5869	PISTON ASS'Y	1	INCLUD. 16, 17
19	669-5441	BOLT 4 X 12PS	2	
20	668-8096	FRONT HANDLE	1	
21	669-5054	HEX. HOLE BOLT 5 X 40	2	
22	668-4834	SPRING WASHER 5	2	
23	668-9680	BRAKE SHAFT WASHER	2	
24	668-8494	CLUTCH	1	
25	668-8570	CLUTCH DRUM COMP.	1	
26	669-5538	BALL BEARING #6002Z, 32MM/OD	2	
27	669-5285	STOP RING C-15, OUTER	1	
28	668-4786	HEX. SOCKET HD. BOLT M5 X 30S	3	
29	669-1822	ANTI-VIBE RUBBER	1	
30	668-4607	OIL SEAL TB 12227	2	
31	668-4608	BALL BEARING 6001 C3	2	
32	668-6720	CRANKCASE GASKET	1	
33	669-5521	KNOCK PIN 4 X 12	2	
34	668-6771	STUD BOLT 6 X 22	2	
35	668-6574	CRANK CASE ASS'Y	1	INCLUD. 30-34
36	669-3237	STARTER HANDLE	1	
37	669-3172	ROPE 3 X 890	1	
38		HITACHI LABEL	1	
39		NAME PLATE	1	
40	669-5502	HEX. HOLE BOLT 4 X 18PS	3	
41	668-7014	FAN CASE COMP.	1	
42		CAUTION MARK (A)	1	
43	668-4675	RECOIL SPRING	1	
44	669-3072	STARTER ROPE REEL	1	
45	668-4677	DUMPER SPRING	1	
46	668-4678	CAM PLATE	1	
47	668-4679	SET SCREW	1	
48	668-4685	STARTER PAWL	2	
49	668-4684	STARTER PAWL SPRING	2	

**PARTS**

CH 62EA3

ITEM NO.	CODE NO.	DESCRIPTION	NO. USED	REMARKS
50	668-4683	STOP RING E-5	2	
51	668-4681	STARTER PULLEY ASS'Y	1	INCLUD. 48-50
52	668-7209	DEFLECTOR	1	
53	668-4612	HEX. NUT M8	1	
54	668-7396	MAGNETO ROTOR COMP.	1	
55	669-6342	HANDLE A	1	
56	669-6350	EARTH TERMINAL	1	
57	696-352	TAPPING SCREW D3	3	
58	669-6344	SAFETY LEVER	1	
59	669-6345	THROTTLE LEVER SPRING	1	
60	669-6355	TAB TERMINAL	2	
61	668-4913	SCREW 3 X 10	1	
62	668-8366	BUTTON STOP	1	
63	669-4588	STOP BUTTON MARK	1	
64	669-6348	SPRING (A)	1	
65	669-6349	SPRING (B)	1	
66	669-6343	THROTTLE LEVER	1	
67	669-6346	LOCK LEVER	1	
68	669-6347	RELEASE LEVER	1	
69	669-6351	THROTTLE WIRE COMP.	1	
70	668-7521	PROTECTION TUBE 130L	1	
71	669-6354	STOP SWITCH ASS'Y (A)	1	INCLUD. 61-63
72	669-6353	HANDLE (B)	1	
73	305-812	TAPPING SCREW (W/FLANGE) D4 X 16 (BLACK)	4	
91	668-4636	TAPPING SCREW D4.5 X 16	1	
92	669-2795	MUFFLER PROTECTOR	1	
93	668-5114	HEX. SOCKET HD. BOLT M5 X 50	2	
94	668-4661	WASHER 5	2	
95	669-2481	MUFFLER SET	1	INCLUD. 97
96	668-7252	HEAT SHIELD	1	
97	669-2744	MUFFLER GASKET	1	
98	668-9891	INTAKE PIPE GASKET	1	
99	668-9966	CARB. INSULATOR SET, SPARE	1	INCLUD. 98
100	669-5515	HEX. HOLE BOLT 5 X 25WS	2	
101	668-9839	CARBURETOR GASKET	1	
102	668-4629	THROTTLE WIRE FIXING PLATE	1	
103	668-4615	CARBURETOR GASKET	1	
104	669-0495	CARBURETOR SET WYL212	1	INCLUD. 103, 116-131
105	668-4628	SWIVEL CAP	1	
106	669-0184	CLEANER GASKET	1	
107	669-0091	CLEANER BODY COMP.	1	
108	669-0801	COLLAR	2	
109	669-1267	CHOKE PLATE, W/1.5MM HOLE	1	
110	668-4859	SPACER	1	
111	668-4661	WASHER 5	2	
112	668-4662	S. WASHER 5	2	
113	669-4918	SCREW 5 X 65	2	
114	669-0350	CLEANER ELEMENT	1	
115	669-0142	AIR CLEANER CAP	1	
116	668-4697	SWIVEL	1	

**PARTS**

CH 62EA3

ITEM NO.	CODE NO.	DESCRIPTION	NO. USED	REMARKS
117	668-4696	STOP RING	1	
118	668-4695	O-RING	1	
119	668-4878	MAIN JET #39	1	
120	668-4700	INLET SCREEN	1	
121	669-1433	PUMP BODY COMP.	1	
122	668-4687	PRIMING PUMP COMP.	1	
123	668-4688	DIAPHRAGM COVER	1	
124	668-4699	SET SCREW	4	
125	668-4698	THROTTLE SET SCREW	2	
126	668-4883	THROTTLE VALVE	1	
127	669-1457	PUMP GASKET	1	
128	668-4693	PUMP DIAPHRAGM	1	
129	668-4691	DIAPHRAGM GASKET	1	
130	669-0830	METERING DIAPHRAGM COMP.	1	
131	668-4689	PRIMING BODY	1	
132	669-6356	TANK	1	
133	668-4625	TANK CAP CHAIN	1	
134	669-1763	TANK CAP D ASS'Y, BLACK	1	INCLUD. 133
135	669-2244	COLLAR 5.8	2	
136	669-5505	HEX. HOLE BOLT 5 X 18PS	2	
137	668-4619	CLIP, 6.3 DIA.	1	
138	668-4620	PUMP FILTER BODY COMP.	1	
139	668-5247	SHIELD TUBE	1	
140	668-4626	FUEL PIPE 3 X 5 X 65	1	
141	668-4627	RETURN GROMMET	1	
142	668-8643	GREASE NIPPLE COMP.	1	
143	305-491	NYLON NUT M5	2	
144	668-4864	SMALL WASHER 5	2	
145	669-5175	NUT 6 UPS-P	1	
146	668-4639	WASHER 6	1	
147	669-0761	SUPPORT PLATE	1	
148	668-7302	CUTTER COVER	1	
149	669-5170	FLANGE NUT 6	4	
150	669-6917	CLICK SPRING	1	
151	669-6358	GEAR CASE (A)	1	INCLUD. 156
152	668-8008	CORD CLAMP COMP.	1	
153	669-5475	SPRING NUT 6	2	
154	669-5495	HEX. HOLE BOLT 6 X 18/S	2	
155	669-6359	CLIP	1	
156	668-8960	GEAR SHAFT	1	
157	668-7153	CUTTER GUIDE 680L	1	
158	668-6614	GUIDE PLATE	1	
159	668-7096	CUTTER A 620L	1	
160	668-8979	GEAR 2	1	
161	668-7120	CUTTER B 620L	1	
162	668-6468	HOLDING PLATE	1	
163	668-8909	GEAR CASE GASKET	1	
164	669-2102	GEAR CASE COVER	1	
165	669-5484	HEX. HOLE BOLT 4 X 10S	6	
166	668-6658	GREASE SEAL A	2	

