

ELECTRIC TOOL PARTS LIST

CUT METAL SAW
Model CD 7SA

2008·4·4
(E1)

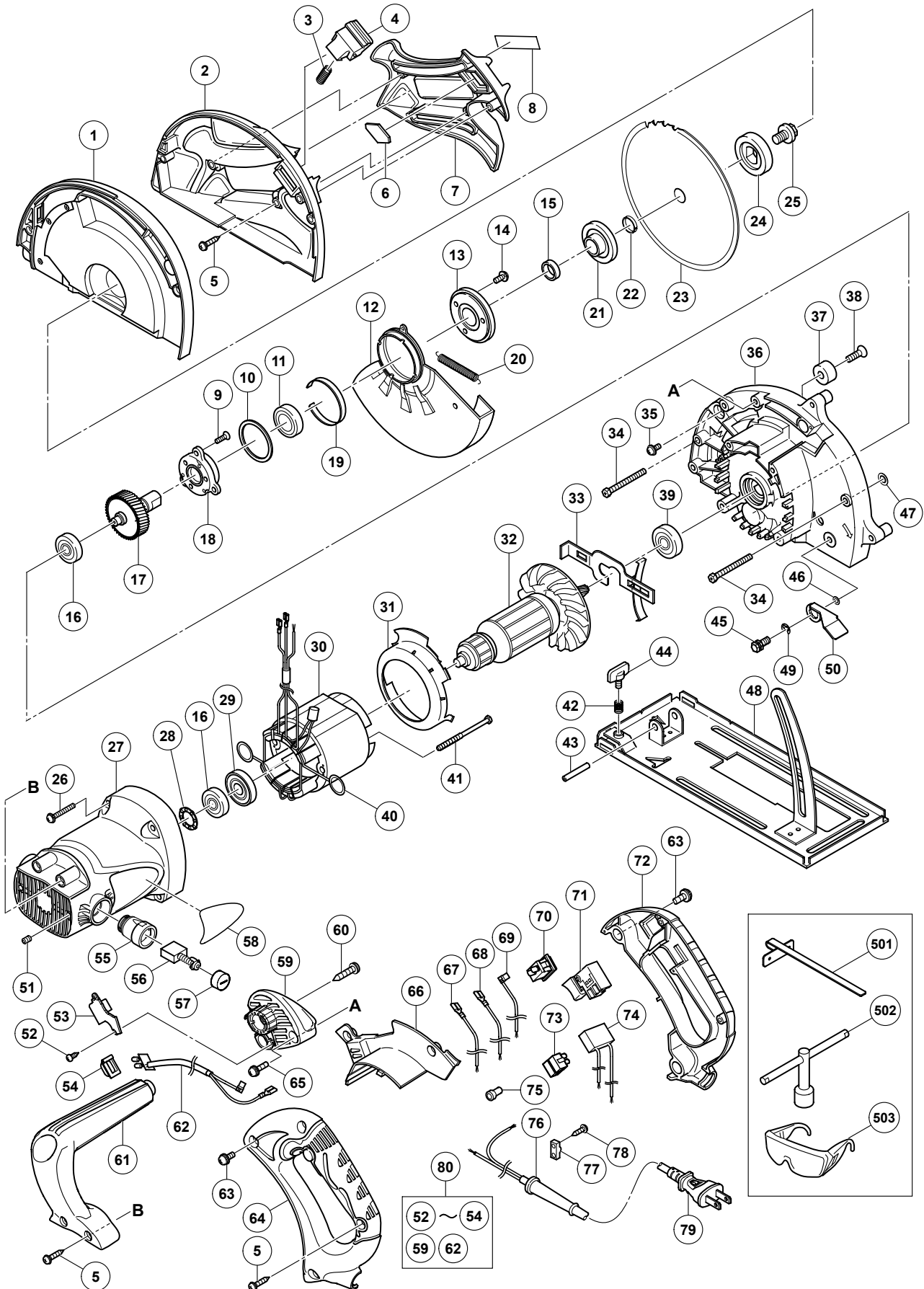

PARTS

CD 7SA

ITEM NO.	CODE NO.	DESCRIPTION	NO. USED	REMARKS
1	329-200	DUST COVER (A)	1	
2	329-201	DUST COVER (B)	1	
3	329-204	SPRING	1	
4	329-202	KNOB	1	
5	301-653	TAPPING SCREW (W/FLANGE) D4X20 (BLACK)	7	
6	329-205	GLASS PLATE	1	
7	329-206	DUST COVER (C)	1	
8		HITACHI PLATE	1	
9	305-568	SEAL LOCK FLAT HD. SCREW M5X12	3	
10	329-736	WASHER	1	
11	620-2VV	BALL BEARING 6202VVCMP2L	1	
12	329-216	LOWER GUARD	1	
13	330-043	BEARING CAP	1	
14	307-635	MACHINE SCREW (W/SP. WASHER) M4X10	3	
15	961-366	DISTANCE PIECE	1	
16	608-VVM	BALL BEARING 608VVC2PS2L	2	
* 17	329-197	SPINDLE AND GEAR SET	1	
* 17	329-737	SPINDLE AND GEAR SET	1	FOR USA, CAN
18	329-198	BEARING HOLDER	1	
19	961-807	BUSHING	1	
20	957-062	RETURN SPRING	1	
* 21	993-598	WASHER (A)	1	
* 21	329-738	WASHER (A1)	1	FOR GBR, EUROPE, AUT
* 21	329-739	WASHER (A2)	1	FOR USA, CAN
* 22	990-100	RING D15.9/I.D14.5	1	FOR USA, CAN
23	307-276	TCT SAW BLADE 185MM-D20 HOLE-NT38	1	
24	957-064	WASHER (B)	1	
25	957-749	BOLT (W/WASHER) M7X17.5	1	
26	303-796	MACHINE SCREW (W/WASHERS) M5X40 (BLACK)	4	
27	329-193	HOUSING ASS'Y	1	INCLUD. 51, 55
28	316-394	THRUST WASHER	1	
29	315-877	DUST SEAL	1	
* 30	340-715D	STATOR ASS'Y 110V	1	INCLUD. 40
* 30	340-715C	STATOR ASS'Y 120V	1	INCLUD. 40
* 30	340-715E	STATOR ASS'Y 220V-230V	1	INCLUD. 40
* 30	340-715F	STATOR ASS'Y 240V	1	INCLUD. 40
31	329-194	FAN GUIDE	1	
* 32	360-829U	ARMATURE ASS'Y 110V-120V	1	INCLUD. 16, 29, 39
* 32	360-829E	ARMATURE 220V-230V	1	
* 32	360-829F	ARMATURE 240V	1	
33	329-195	LOCK LEVER	1	
34	329-218	BOLT (+HD.) M6X38	2	
35	304-043	MACHINE SCREW (W/WASHERS) M4X10 (BLACK)	2	
36	329-196	GEAR COVER	1	
37	961-729	CUSHION	1	
38	949-794	FLAT HD. SCREW M6X20 (10 PCS.)	1	
39	600-1VV	BALL BEARING 6001VVCMP2L	1	
40	930-703	BRUSH TERMINAL	2	
41	961-400	HEX. HD. TAPPING SCREW D5X70	2	
42	941-056	SPRING	1	

PARTS

CD 7SA

ITEM NO.	CODE NO.	DESCRIPTION	NO USED	REMARKS
43	949-576	ROLL PIN D6X32 (10 PCS.)	1	
44	307-947	WING BOLT M6X12	1	
45	329-729	SPECIAL BOLT M6	1	
46	949-425	WASHER M6 (10 PCS.)	1	
47	307-292	O-RING (4PC-5)	2	
48	329-199	BASE	1	
49	942-827	RETAINING RING (E-TYPE) FOR D8 SHAFT	1	
50	329-730	LINK LEVER	1	
51	938-477	HEX. SOCKET SET SCREW M5X8	2	
52	323-239	TAPPING SCREW D2.6X10	2	
53	329-740	LED COVER (B)	1	
54	329-732	LED HOLDER	1	
55	958-900	BRUSH HOLDER	2	
* 56	999-056	CARBON BRUSH (1 PAIR)	2	
* 56	999-043	CARBON BRUSH (1 PAIR)	2	FOR USA, CAN, GBR (110V), TPE
57	945-161	BRUSH CAP	2	
58		NAME PLATE	1	
59	329-217	SIDE HANDLE (A)	1	
60	305-558	TAPPING SCREW (W/FLANGE) D5X25 (BLACK)	1	
61	329-741	SIDE HANDLE (B)	1	
* 62	329-734	LED 100V-120V	1	
* 62	329-742	LED 220V-240V	1	
63	307-294	MACHINE SCREW (W/WASHERS) M5X16 (BLACK)	4	
64	329-214	HANDLE (A)	1	
65	316-229	MACHINE SCREW (W/WASHERS) M5X20 (BLACK)	2	
66	329-207	LED COVER (A)	1	
* 67	330-044	INTERNAL WIRE (A)	1	EXCEPT FOR USA, CAN
68	329-213	INTERNAL WIRE (A)	1	
69	330-045	INTERNAL WIRE	1	
70	319-503	SWITCH (W/COVER)	1	
71	324-424	SWITCH (3P FASTON TYPE) W/O LOCK	1	
72	329-215	HANDLE (B)	1	
73	938-307	PILLAR TERMINAL	2	
* 74	930-039	NOISE SUPPRESSOR	1	EXCEPT FOR USA, CAN, GBR (110V), TPE
* 74	930-039	NOISE SUPPRESSOR	2	FOR GBR (110V), TPE
* 75	959-141	CONNECTOR 50092 (10 PCS.)	1	EXCEPT FOR USA, CAN
* 76	953-327	CORD ARMOR D8.8	1	
* 76	938-051	CORD ARMOR D10.1	1	
77	937-631	CORD CLIP	1	
78	984-750	TAPPING SCREW (W/FLANGE) D4X16	2	
* 79	500-234Z	CORD	1	(CORD ARMOR D8.8)
* 79	500-439Z	CORD	1	(CORD ARMOR D8.8) FOR NZL, AUS
* 79	500-453Z	CORD	1	(CORD ARMOR D10.1) FOR USA, CAN
* 79	500-435Z	CORD	1	(CORD ARMOR D8.8) FOR GBR (230V), HKG
* 79	500-461Z	CORD	1	(CORD ARMOR D10.1) FOR GBR (110V)
* 79	500-455Z	CORD	1	(CORD ARMOR D8.8) FOR CHN
* 79	500-474Z	CORD	1	(CORD ARMOR D10.1) FOR TPE
* 80	329-743	SIDE HANDLE (A) ASS'Y 110V-120V	1	INCLUD. 52-54, 59, 62
* 80	329-744	SIDE HANDLE (A) ASS'Y 220V-240V	1	INCLUD. 52-54, 59, 62

