

## ELECTRIC TOOL PARTS LIST

■ CIRCULAR SAW  
Model C 7SB2

2005 · 7 · 8  
(E2)

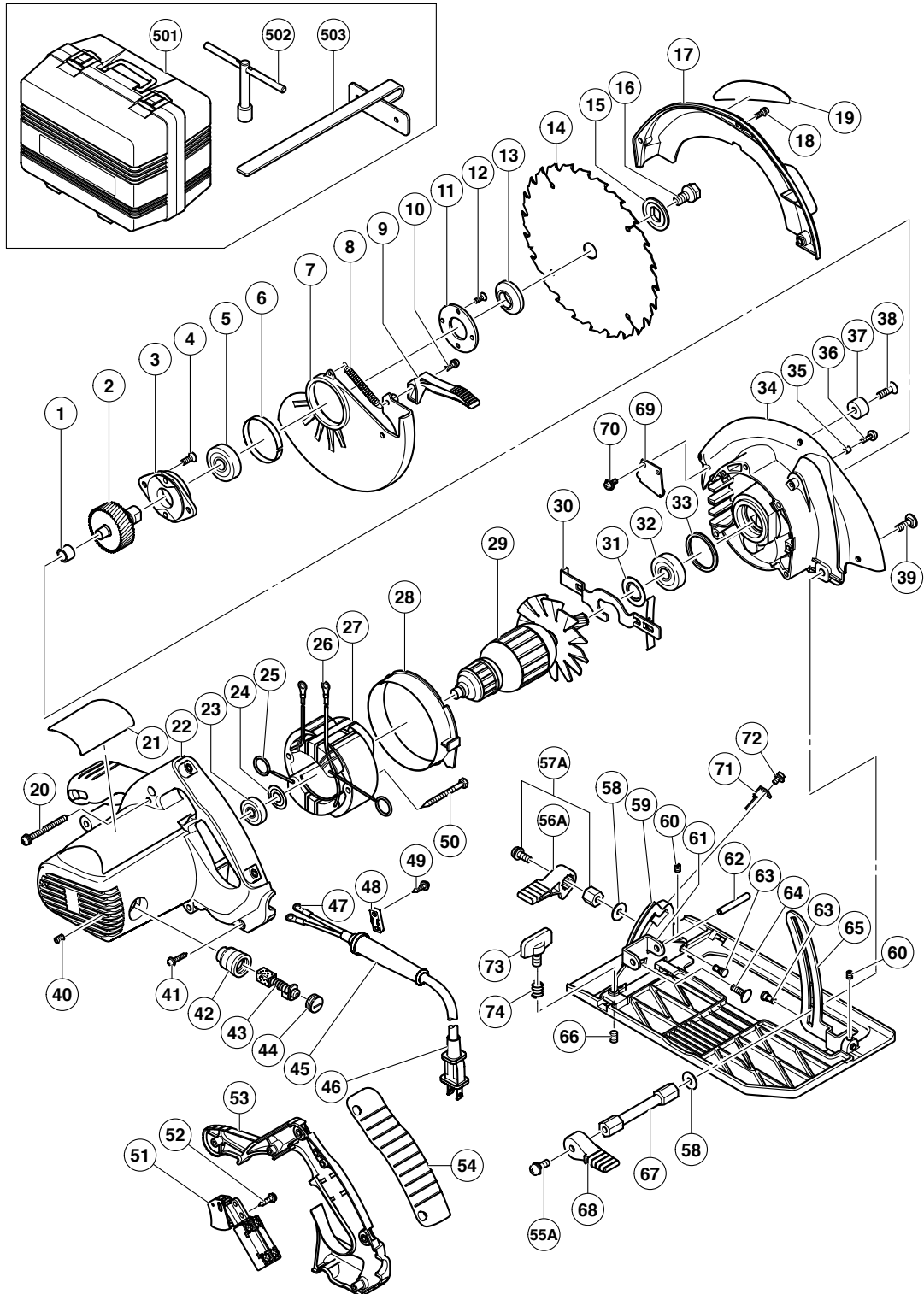

**PARTS**

C 7SB2

ITEM NO.	CODE NO.	DESCRIPTION	NO. USED	REMARKS
1	982-027	NEEDLE BEARING (HK1010)	1	
2	320-960	SPINDLE AND GEAR SET	1	
3	302-433	BEARING HOLDER	1	
4	992-013	SEAL LOCK FLAT HD. SCREW M5X14	2	
5	600-3VV	BALL BEARING 6003VVCMP2L	1	
6	961-807	BUSHING	1	
7	320-956	LOWER GUARD	1	
8	320-968	RETURN SPRING	1	
9	320-957	LEVER	1	
10	935-196	MACHINE SCREW (W/WASHERS) M4X12 (BLACK)	1	
11	302-435	BEARING COVER	1	
12	990-430	SEAL LOCK FLAT HD. SCREW M4X10	2	
* 13	320-970	WASHER (A)	1	
* 13	321-639	WASHER (A)	1	FOR AUS, NZL
* 13	324-597	WASHER (A)	1	FOR EUROPE
* 14	320-843	TCT SAW BLADE 185MM-D16 HOLE-NT24	1	
* 14	302-411	TCT SAW BLADE 185MM-D20 HOLE-NT18	1	FOR AUS, NZL
* 14	302-412	TCT SAW BLADE 185MM-D30 HOLE-NT18	1	FOR EUROPE
* 15	320-953	WASHER (B)	1	
* 15	324-598	WASHER (B)	1	FOR EUROPE
16	320-971	BOLT (W/FLANGE) M8X15.5	1	
17	324-594	BLADE COVER	1	
18	951-039	MACHINE SCREW (W/SP. WASHER) M4X12	3	
19		HITACHI LABEL	1	
20	308-357	MACHINE SCREW (W/WASHERS) M5X55	3	
21		NAME PLATE	1	
22	320-951	HOUSING ASS'Y	1	INCLUD. 40, 42
23	600-0VV	BALL BEARING 6000VVCMP2L	1	
24	302-428	WASHER (A)	1	
25	937-623	BRUSH TERMINAL	2	
26	930-804	TERMINAL M4.0 (10 PCS.)	2	
* 27	340-638G	STATOR ASS'Y 110V	1	INCLUD. 25, 26
* 27	340-528C	STATOR ASS'Y 120V	1	INCLUD. 25, 26
* 27	340-528G	STATOR ASS'Y 220V-230V	1	INCLUD. 25, 26
* 27	340-528H	STATOR ASS'Y 240V	1	INCLUD. 25, 26
28	320-958	FAN GUIDE	1	
* 29	360-577U	ARMATURE ASS'Y 110V-120V	1	INCLUD. 23, 24, 31, 32
* 29	360-577G	ARMATURE 220V-230V	1	
* 29	360-577H	ARMATURE 240V	1	
30	320-959	LOCK LEVER	1	
31	980-700	DUST WASHER (B)	1	
32	620-2VV	BALL BEARING 6202VVCMP2L	1	
33	303-792	RUBBER RING	1	
* 34	320-954	GEAR COVER	1	
* 34	324-600	GEAR COVER	1	FOR EUROPE
35	311-837	SPACER M4	1	
36	311-836	TP-SCREW M4X14	1	
37	961-729	CUSHION	1	
38	949-794	FLAT HD. SCREW M6X20 (10 PCS.)	1	
39	942-808	BOLT (SQUARE) M6X20	1	
40	938-477	HEX. SOCKET SET SCREW M5X8	2	

**PARTS**

ITEM NO.	CODE NO.	DESCRIPTION	NO. USED	REMARKS
41	301-653	TAPPING SCREW (W/FLANGE) D4X20 (BLACK)	5	
42	938-241	BRUSH HOLDER	2	
43	999-038	CARBON BRUSH (1 PAIR)	2	
44	945-161	BRUSH CAP	2	
* 45	958-049	CORD ARMOR D8.2	1	
* 45	940-778	CORD ARMOR D10.7	1	
* 46	500-453Z	CORD	1	(CORD ARMOR D10.7)
* 46	500-439Z	CORD	1	(CORD ARMOR D8.2) FOR AUS, NZL
* 46	500-435Z	CORD	1	(CORD ARMOR D8.2) FOR GBR (230V)
* 46	500-463Z	CORD	1	(CORD ARMOR D10.7) FOR GBR (110V)
* 46	500-234Z	CORD	1	(CORD ARMOR D8.2) FOR EUROPE
* 47	930-804	TERMINAL M4.0 (10 PCS.)	2	
* 47	980-063	TERMINAL	2	FOR AUS, NZL, EUROPE
48	937-631	CORD CLIP	1	
49	984-750	TAPPING SCREW (W/FLANGE) D4X16	2	
50	953-121	HEX. HD. TAPPING SCREW D5X50	2	
51	320-969	SWITCH (2P SCREW TYPE)	1	
52	305-720	TAPPING SCREW (W/FLANGE) D4X12	1	
53	320-952	HANDLE COVER	1	
54	320-967	GRIP COVER	1	
55A	322-260	SEAL LOCK SCREW (W/SP. WASHERS) M6X14	1	
56A	322-600	LEVER (A) W/STOPPER	1	
57A	322-261	LOCK NUT SET (W/SCREW)	1	
58	320-975	WASHER	2	
* 59	320-961	BASE ASS'Y	1	INCLUD. 55-58, 60, 61, 63-66
* 59	324-599	BASE ASS'Y	1	INCLUD. 55-58, 60, 61, 63-66, 71-74 FOR EUROPE
60	319-541	SEAL LOCK HEX. SOCKET SET SCREW M5X6	2	
61	320-962	BEVEL PLATE	1	
62	949-686	ROLL PIN D6X40 (10 PCS.)	1	
63	320-163	STEP PIN D6X13	2	
64	942-808	BOLT (SQUARE) M6X20	1	
65	320-963	LINK	1	
66	308-109	SLOTTED HD. SET SCREW (SEAL LOCK) M6X8	1	
67	320-966	LONG NUT	1	
68	322-601	LEVER (A) W/O STOPPER	1	
* 69	324-596	PLATE	1	FOR EUROPE
* 70	958-523	MACHINE SCREW (W/SP. WASHER) M4X8	2	FOR EUROPE
* 71	324-595	STOPPER	1	FOR EUROPE
* 72	958-523	MACHINE SCREW (W/SP. WASHER) M4X8	1	FOR EUROPE
* 73	301-806	WING BOLT M6X15	1	FOR AUS, NZL, EUROPE
* 74	947-859	LOCK SPRING	1	FOR AUS, NZL, EUROPE

### STANDARD ACCESSORIES

C 7SB2

ITEM NO.	CODE NO.	DESCRIPTION	NO. USED	REMARKS	
501	321-188	CASE	1		
502	940-543	BOX WRENCH 10MM	1		
* 503	302-691	GUIDE	1	FOR AUS, NZL, EUROPE	

### OPTIONAL ACCESSORIES

ITEM NO.	CODE NO.	DESCRIPTION	NO. USED	REMARKS	
601	302-691	GUIDE	1		