

ELECTRIC TOOL PARTS LIST

COMPOUND SAW Model C 10FCH

2004 • 12 • 15

(E2)

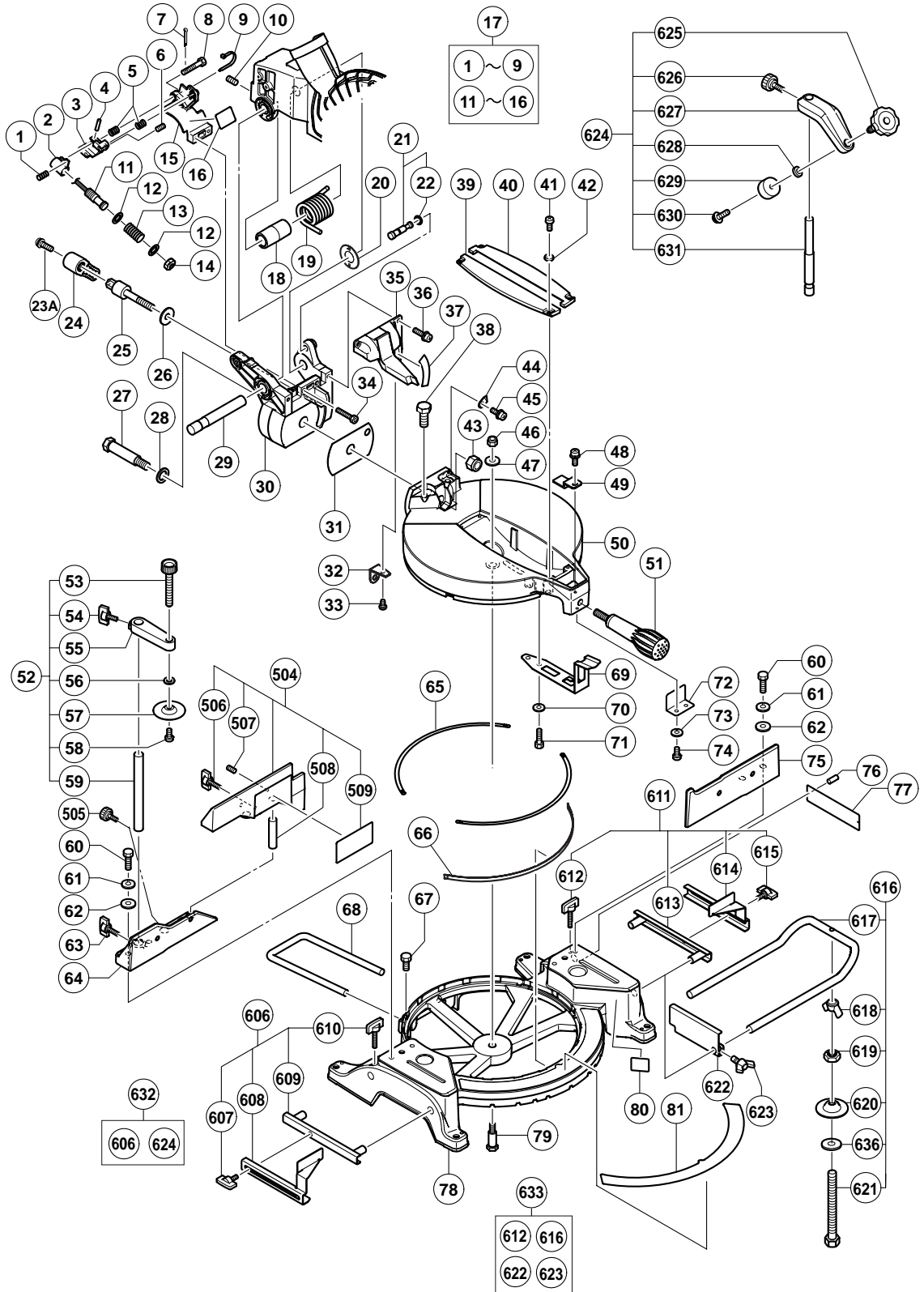

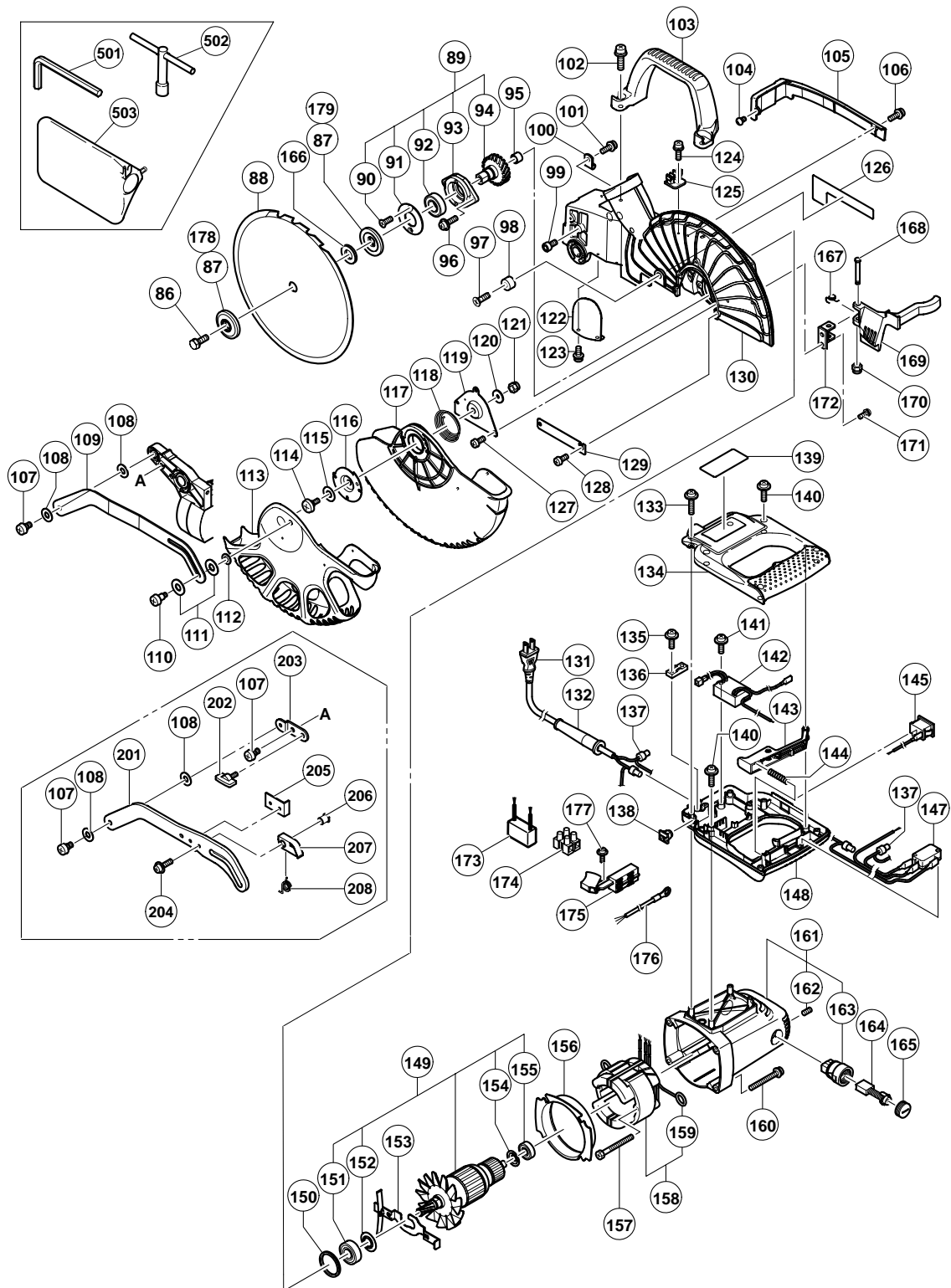

PARTS

C 10FCH

ITEM NO.	CODE NO.	DESCRIPTION	NO. USED	REMARKS
1	323-141	SPRING (B)	1	
2	323-137	LASER HOLDER (A)	1	
3	323-138	LASER HOLDER (B)	1	
4	949-900	ROLL PIN D3X14 (10 PCS.)	1	
5	323-142	SPRING (C)	2	
6	962-782	HEX. SOCKET SET SCREW M5X6	1	
7	949-531	SPLIT PIN D2X12 (10 PCS.)	1	
8	323-144	SPECIAL BOLT M5	1	
9	975-144	CABLE TIE	3	
10	307-956	SEAL LOCK HEX. SOCKET SET SCREW M6X10	1	
11	323-135	LASER MODULE	1	
12	323-143	WASHER	2	
13	323-140	SPRING (A)	1	
14	323-136	LASER COVER	1	
15	323-139	LASER BASE ASS'Y	1	INCLUD. 16
16		CAUTION LABEL (A)	1	
17	322-927	LASER HOLDER ASS'Y	1	INCLUD. 1-9, 11-15
18	322-889	SLEEVE	1	
19	322-890	SPRING	1	
20	322-965	LINER (D)	1	
21	302-518	STOPPER PIN ASS'Y	1	INCLUD. 22
22	984-528	O-RING (P-6)	1	
23	997-314	MACHINE SCREW (W/WASHERS) M6X10	1	
24	322-935	CLAMP LEVER	1	
25	322-936	BOLT (LEFT HAND) M10	1	
26	318-934	SPECIAL WASHER	1	
27	322-933	SHAFT (D)	1	
28	322-934	WASHER M16	1	
29	322-888	SHAFT (C)	1	
30	322-932	HINGE	1	
31	322-937	LINER (B)	1	
32	322-963	DUST GUIDE HOLDER	1	
33	949-215	MACHINE SCREW M4X8 (10 PCS.)	1	
34	949-652	HEX. SOCKET HD. BOLT M6X25 (10 PCS.)	2	
35	322-891	DUST GUIDE ASS'Y	1	INCLUD. 32, 33, 37
36	990-541	MACHINE SCREW (W/WASHERS) M5X16	2	
37	322-892	SCALE (B)	1	
38	303-409	NYLOCK BOLT M8X25	2	
39	322-930	TABLE INSERT (B)	1	
40	322-929	TABLE INSERT (A)	1	
41	949-217	MACHINE SCREW M4X12 (10 PCS.)	4	
42	949-429	BOLT WASHER M4 (10 PCS.)	4	
43	680-418	NYLON NUT M12	1	
44	322-893	INDICATOR (B)	1	
45	304-043	MACHINE SCREW (W/WASHERS) M4X10 (BLACK)	1	
46	975-348	NYLON NUT M8	1	
47	318-929	WASHER (F)	1	
48	304-043	MACHINE SCREW (W/WASHERS) M4X10 (BLACK)	1	
49	322-904	INDICATOR (A)	1	
50	322-897	TURN TABLE	1	
51	322-898	SIDE HANDLE	1	

PARTS

C 10FCH

ITEM NO.	CODE NO.	DESCRIPTION	NO. USED	REMARKS
52	322-952	WISE ASS'Y	1	INCLUD. 53-59
53	302-522	KNOB BOLT M10X66	1	
54	301-806	WING BOLT M6X15	1	
55		SCREW HOLDER	1	
56	949-432	BOLT WASHER M6 (10 PCS.)	1	
57	302-532	WISE PLATE	1	
58	949-216	MACHINE SCREW M4X10 (10 PCS.)	1	
59	322-954	WISE SHAFT	1	
60	949-678	BOLT M8X35 (10 PCS.)	4	
61	949-457	SPRING WASHER M8 (10 PCS.)	4	
62	949-433	BOLT WASHER M8 (10 PCS.)	4	
63	301-806	WING BOLT M6X15	1	
64	322-906	FENCE (B)	1	
65	322-901	LINER (A)	2	
66	322-964	LINER (C)	1	
67	949-610	BOLT M6X10 (10 PCS.)	1	
68	322-910	HOLDER	1	
69	322-903	SPRING PLATE	1	
70	949-457	SPRING WASHER M8 (10 PCS.)	2	
71	949-655	HEX. SOCKET HD. BOLT M8X16 (10 PCS.)	2	
72	322-899	SPACER	1	
73	949-453	SPRING WASHER M4 (10 PCS.)	2	
74	949-215	MACHINE SCREW M4X8 (10 PCS.)	2	
75	322-905	FENCE (A)	1	
* 76	949-510	RIVET D2.5X4.8 (10 PCS.)	3	FOR USA, CAN
* 77		CAUTION LABEL (D)	1	
* 77	322-896	WARNING LABEL (A)	1	FOR USA, CAN
* 78	323-976	BASE ASS'Y	1	INCLUD. 77, 81
* 78	322-894	BASE ASS'Y	1	INCLUD. 76, 77, 80, 81 FOR USA, CAN
79	322-902	SHAFT (B)	1	
* 80		CAUTION LABEL (C)	1	FOR USA, CAN
81	322-895	SCALE (A)	1	
86	998-335	BOLT (LEFT HAND) W/WASHER M7X17.5	1	
* 87	308-789	WASHER (D)	2	EXCEPT FOR EUROPE
* 88	318-963	TCT SAW BLADE 255MM-D15.88 HOLE-NT24	1	
* 88	319-107	TCT SAW BLADE 255MM-D30 HOLE-NT30	1	
* 88	319-106	TCT SAW BLADE 255MM-D25.4 HOLE-NT24	1	
* 88	318-964	TCT SAW BLADE 255MM-D25.4 HOLE-NT100	1	
89	323-133	SPINDLE ASS'Y	1	INCLUD. 90-94
90	990-430	SEAL LOCK FLAT HD. SCREW M4X10	2	
91	322-919	BEARING COVER	1	
92	600-3VV	BALL BEARING 6003VVCMP2L	1	
93	322-918	BEARING HOLDER	1	
94	322-917	SPINDLE AND GEAR SET	1	
95	982-027	NEEDLE BEARING (HK1010)	1	
96	987-512	MACHINE SCREW (W/SP. WASHER) M5X16	2	
97	949-340	FLAT HD. SCREW M6X16 (10 PCS.)	1	
98	961-729	CUSHION	1	
99	949-819	HEX. SOCKET HD. BOLT M5X10 (10 PCS.)	1	
100	980-523	NYLON CLIP	1	
101	935-196	MACHINE SCREW (W/WASHERS) M4X12 (BLACK)	1	

PARTS

C 10FCH

ITEM NO.	CODE NO.	DESCRIPTION	NO. USED	REMARKS
102	951-893	MACHINE SCREW (W/WASHERS) M6X20	2	
103	322-924	HANDLE	1	
104	949-215	MACHINE SCREW M4X8 (10 PCS.)	1	
105	322-931	GEAR CASE COVER	1	
106	993-539	MACHINE SCREW (W/WASHERS) M4X16	1	
* 107	322-950	SPECIAL SCREW M6	1	
* 107	322-950	SPECIAL SCREW M6	2	FOR EUROPE
108	322-948	WASHER M7	2	
* 109	322-949	LINK	1	EXCEPT FOR EUROPE
110	322-947	SPECIAL SCREW (C) M5	1	
111	322-938	WASHER M10	2	
112	949-454	SPRING WASHER M5 (10 PCS.)	1	
113	322-940	PROTECTIVE COVER (B)	1	
114	322-943	SPECIAL SCREW (B) M5	1	
115	322-944	WASHER M8	1	
116	322-942	COVER PLATE (B)	1	
117	322-939	PROTECTIVE COVER (A)	1	
118	322-946	RETURN SPRING	1	
119	322-941	COVER PLATE (A)	1	
120	322-945	WASHER M5	1	
121	877-371	NYLON NUT M5	1	
122	322-926	LASER COVER (A)	1	
123	935-196	MACHINE SCREW (W/WASHERS) M4X12 (BLACK)	1	
124	935-196	MACHINE SCREW (W/WASHERS) M4X12 (BLACK)	1	
125	322-920	HOOK	1	
126		CAUTION LABEL (B)	1	
127	949-215	MACHINE SCREW M4X8 (10 PCS.)	3	
* 128	949-215	MACHINE SCREW M4X8 (10 PCS.)	2	FOR USA, CAN, EUROPE, AUS
* 129	322-951	SPINDLE COVER	1	FOR USA, CAN, EUROPE, AUS
130	322-928	GEAR CASE ASS'Y	1	INCLUD. 95, 126
* 131	500-234Z	CORD	1	
* 131	500-453Z	CORD	1	FOR USA, CAN
* 131	500-439Z	CORD	1	FOR AUS, NZL
* 131	500-435Z	CORD	1	FOR GBR (230V)
* 131	500-461Z	CORD	1	FOR GBR (110V)
* 131	500-456Z	CORD	1	FOR CHN
132	940-778	CORD ARMOR D10.7	1	
133	307-028	TAPPING SCREW (W/FLANGE) D4X25 (BLACK)	2	
* 134	323-642	SWITCH HANDLE (C)	1	
* 134	322-921	SWITCH HANDLE (A)	1	FOR USA, CAN
135	984-750	TAPPING SCREW (W/FLANGE) D4X16	2	
136	937-631	CORD CLIP	1	
* 137	959-141	CONNECTOR 50092 (10 PCS.)	4	FOR USA, CAN
138	319-349	CORD BUSH	1	
139		NAME PLATE	1	
140	301-653	TAPPING SCREW (W/FLANGE) D4X20 (BLACK)	6	
141	984-750	TAPPING SCREW (W/FLANGE) D4X16	1	
* 142	323-978	SWITCHING POWER SUPPLY	1	
* 142	322-911	SWITCHING POWER SUPPLY	1	FOR USA, CAN
* 143	323-645	SWITCH LEVER (A)	1	
* 143	322-923	SWITCH LEVER	1	FOR USA, CAN

PARTS

C 10FCH

ITEM NO.	CODE NO.	DESCRIPTION	NO. USED	REMARKS
* 144	322-925	SPRING (D)	1	FOR USA, CAN
145	322-912	SWITCH (A) (W/COVER)	1	
* 146		MONITORING LABEL	1	FOR USA, CAN
* 147	322-913	MICRO SWITCH	1	FOR USA, CAN
* 148	323-694	SWITCH HANDLE (D) ASS'Y	1	
* 148	322-922	SWITCH HANDLE (B)	1	FOR USA, CAN
* 149	360-656U	ARMATURE ASS'Y 110V-120V	1	INCLUD. 151, 152, 154, 155
* 149	360-695E	ARMATURE ASS'Y 220V-230V	1	INCLUD. 151, 152, 154, 155
* 149	360-695F	ARMATURE ASS'Y 240V	1	INCLUD. 151, 152, 154, 155
150	303-792	RUBBER RING	1	
151	620-2VV	BALL BEARING 6202VVCMP2L	1	
152	980-700	DUST WASHER (B)	1	
153	322-916	LOCK LEVER	1	
154	302-428	WASHER (A)	1	
155	600-0VV	BALL BEARING 6000VVCMP2L	1	
156	322-915	FAN GUIDE	1	
157	953-121	HEX. HD. TAPPING SCREW D5X50	2	
* 158	340-591D	STATOR ASS'Y 110V	1	INCLUD. 159
* 158	340-591C	STATOR ASS'Y 120V	1	INCLUD. 159
* 158	340-591E	STATOR ASS'Y 220V	1	INCLUD. 159
* 158	340-615E	STATOR ASS'Y 230V	1	INCLUD. 159
* 158	340-615F	STATOR ASS'Y 240V	1	INCLUD. 159
159	937-623	BRUSH TERMINAL	2	
160	322-123	MACHINE SCREW (W/WASHERS) M5X40 (BLACK)	4	
161	322-914	HOUSING ASS'Y	1	INCLUD. 162, 163
162	938-477	HEX. SOCKET SET SCREW M5X8	2	
163	938-241	BRUSH HOLDER	2	
* 164	999-038	CARBON BRUSH (1 PAIR)	2	FOR 110V-120V
* 164	999-065	CARBON BRUSH (1 PAIR)	2	FOR 220V-240V
165	945-161	BRUSH CAP	2	
* 166	976-819	COLLAR (B) FOR D25.4 HOLE	1	EXCEPT FOR USA, CAN
* 166	974-663Z	COLLAR (A) FOR D30 HOLE	1	FOR EUROPE
* 167	323-987	LEVER SPRING	1	FOR EUROPE
* 168	323-990	LEVER SHAFT	1	FOR EUROPE
* 169	323-979	LOCK LEVER (C)	1	FOR EUROPE
* 170	877-371	NYLON NUT M5	1	FOR EUROPE
* 171	949-236	MACHINE SCREW M5X10 (10 PCS.)	2	FOR EUROPE
* 172	323-982	LEVER HOLDER	1	FOR EUROPE
* 173	930-039	NOISE SUPPRESSOR	1	EXCEPT FOR USA, CAN, CHN
* 174	958-308Z	PILLAR TERMINAL (A)	1	EXCEPT FOR USA, CAN
* 175	320-950	SWITCH (1P SCREW TYPE)	1	EXCEPT FOR USA, CAN
* 176	323-983	INTERNAL WIRE (D)	1	EXCEPT FOR USA, CAN
* 177	984-750	TAPPING SCREW (W/FLANGE) D4X16	1	EXCEPT FOR USA, CAN
* 178	318-962	WASHER (B)	1	FOR EUROPE
* 179	318-961	WASHER (A)	1	FOR EUROPE
* 201	323-980	LINK (A) ASS'Y	1	INCLUD. 204-208 FOR EUROPE
* 202	301-806	WING BOLT M6X15	1	FOR EUROPE
* 203	323-986	TURN PLATE	1	FOR EUROPE
* 204	935-196	MACHINE SCREW (W/WASHERS) M4X12 (BLACK)	3	FOR EUROPE
* 205	323-985	STOP PLATE	1	FOR EUROPE
* 206	323-988	RETURN SHAFT	1	FOR EUROPE

STANDARD ACCESSORIES

C 10FCH

ITEM NO.	CODE NO.	DESCRIPTION	NO. USED	REMARKS
501	944-458	HEX. BAR WRENCH 4MM	1	
502	940-543	BOX WRENCH 10MM	1	
503	322-955	DUST BAG	1	
* 504	322-711	SUB FENCE ASS'Y	1	INCLUD. 506-509
* 504	323-981	SUB FENCE ASS'Y	1	INCLUD. 506-509 FOR EUROPE
505	993-609	KNOB BOLT M6X11	1	
506	322-959	WING BOLT M6X22	1	
507	991-396	HEX. SOCKET SET SCREW M6X6	2	
508	322-958	PIN	2	
* 509		WARNING LABEL (C)	1	
* 509		CAUTION LABEL (E)	1	FOR EUROPE

OPTIONAL ACCESSORIES

ITEM NO.	CODE NO.	DESCRIPTION	NO. USED	REMARKS
606	322-713	CROWN MOLDING STOPPER (L) ASS'Y	1	INCLUD. 607-610
607	301-806	WING BOLT M6X15	1	
608		CROWN MOLDING STOPPER (L)	1	
609	321-390	CROWN MOLDING STOPPER HOLDER	1	
610	316-030	WING BOLT M6X52	1	
611	322-714	CROWN MOLDING STOPPER (R) ASS'Y	1	INCLUD. 612-615
612	316-030	WING BOLT M6X52	2	
613	321-390	CROWN MOLDING STOPPER HOLDER	1	
614		CROWN MOLDING STOPPER (R)	1	
615	301-806	WING BOLT M6X15	1	
616	322-956	HOLDER ASS'Y	1	INCLUD. 617-621, 636
617	321-549	HOLDER	1	
618	949-313	WING NUT M6 (10 PCS.)	1	
619	949-556	NUT M6 (10 PCS.)	1	
620	322-047	WISE PLATE	1	
621	323-134	HIGH TENSION BOLT M6X80	1	
622	974-561	STOPPER	1	
623	949-404	WING BOLT M6X20 (10 PCS.)	1	
624	322-957	WISE (B) ASS'Y	1	INCLUD. 625-631
625	321-551	KNOB BOLT M10X54	1	
626	998-836	KNOB BOLT M6X11	1	
627		SCREW HOLDER (B)	1	
628	306-985	WASHER (H)	1	
629	964-851	BASE RUBBER	1	
630	304-043	MACHINE SCREW (W/WASHERS) M4X10 (BLACK)	1	
631	318-967	WISE SHAFT	1	
632	322-712	CROWN MOLDING VISE ASS'Y	1	INCLUD. 606, 624
633	322-710	GUIDE ASS'Y	1	INCLUD. 612, 616, 622, 623
634	976-472	TCT SAW BLADE CROSS-CUT 255MM-D15.9 HOLE	1	
635	319-658	TCT SAW BLADE 255MM-D15.88 HOLE-NT100	1	
636	949-425	WASHER M6 (10 PCS.)	1	