

Service Manual

Cordless Impact Driver

EY7201-X8

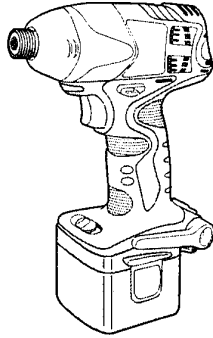

SPECIFICATIONS

MAIN UNIT

Motor	DC Motor 12V
No load speed	soft impact mode : 0-2200/min (rpm)
	hard impact mode : 0-2600/min (rpm)
Maximum torque	soft impact mode : 80.0Nm (820kgf-cm, 711in-lbs.)
	hard impact mode : 120.0Nm (1220kgf-cm, 1060in-lbs.)
Impact per minute	soft impact mode : 0-2100 ipm in Impact Mode
	hard impact mode : 0-2800 ipm in Impact Mode
Overall length	164mm (6-7/16")
Weight (with battery pack)	1.8kg (3.9lbs.)

⚠ WARNING

This service information is designed for experienced repair technicians only and is not designed for use by the general public. It does not contain warnings or cautions to advise non-technical individuals of potential dangers in attempting to service a product. Products powered by electricity should be serviced or repaired only by experienced professional technicians. Any attempt to service or repair the product or products dealt with in this service information by anyone else could result in serious injury or death.

CONTENTS

	Page		Page
1 SCHEMATIC DIAGRAM	2	4 TROUBLESHOOTING GUIDE	5
2 WIRING CONNECTION DIAGRAM	2	5 EXPLODED VIEW	7
3 DISASSEMBLY/ASSEMBLY INSTRUCTIONS	3	6 REPLACEMENT PARTS LIST	8

1 SCHEMATIC DIAGRAM

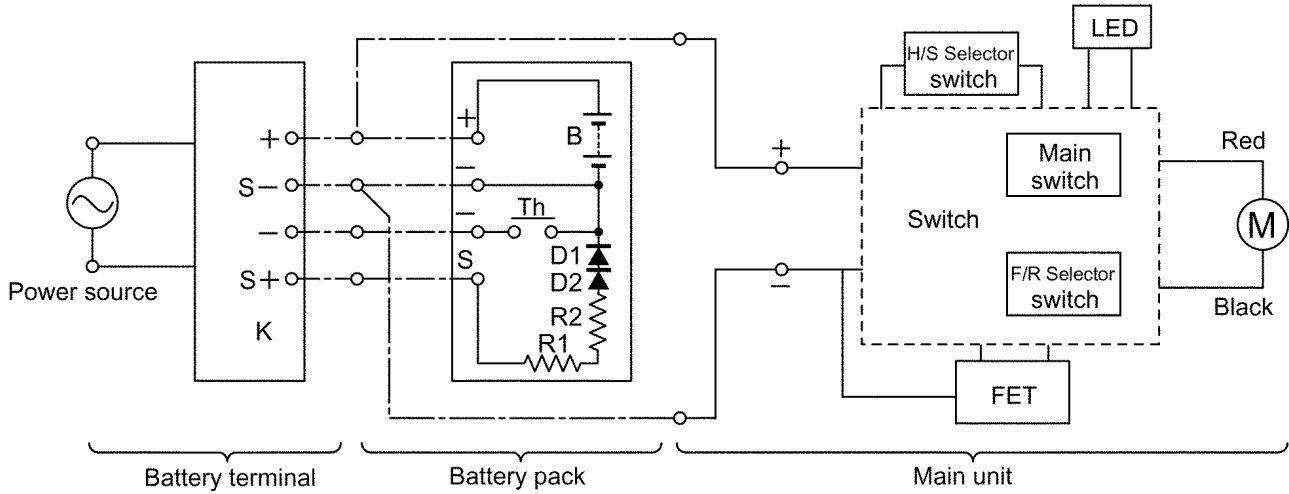

2 WIRING CONNECTION DIAGRAM

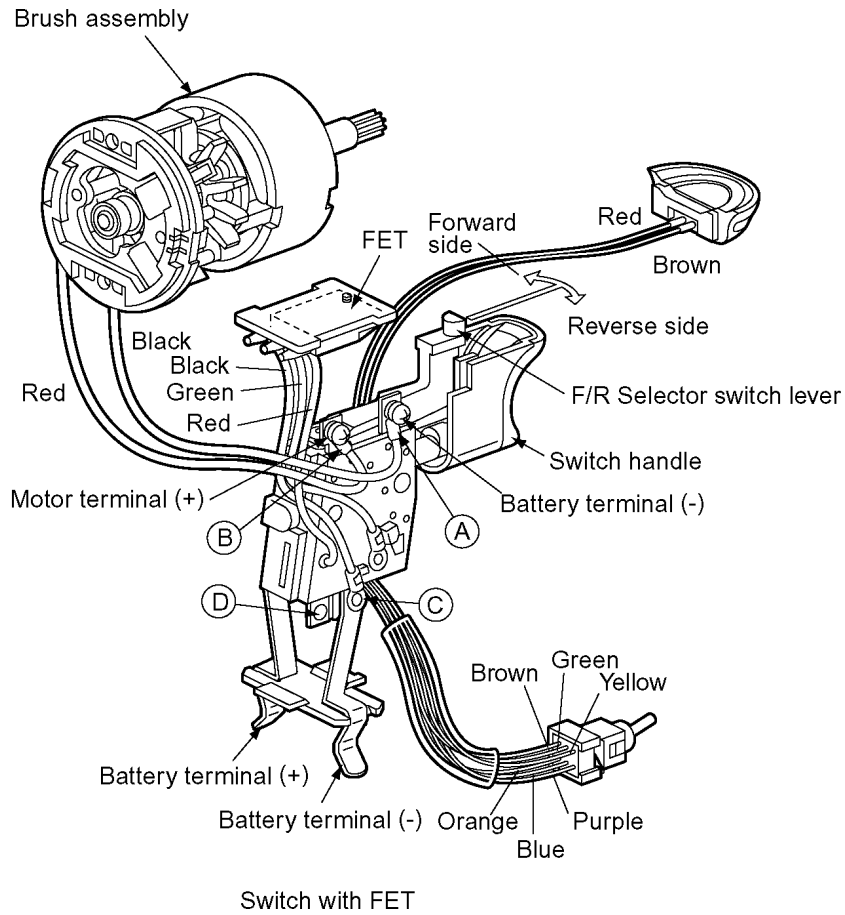

3 DISASSEMBLY/ASSEMBLY INSTRUCTIONS

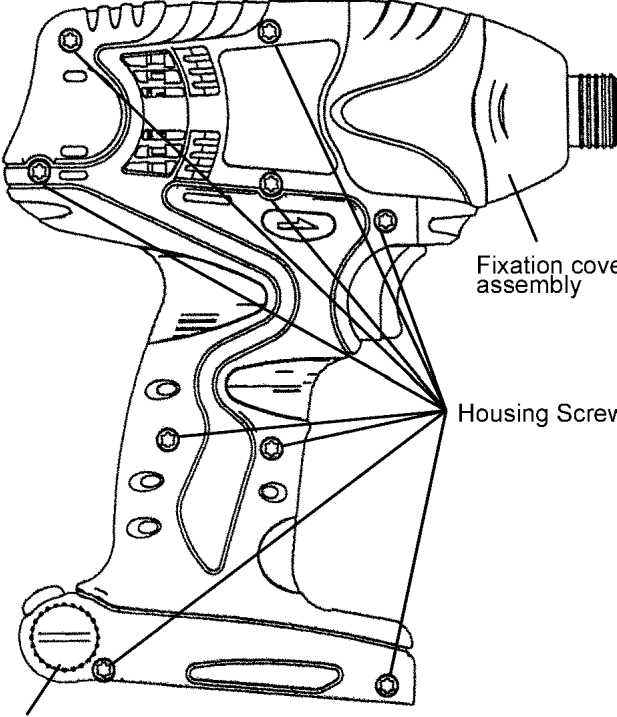
Ref. No. 1A	Procedure 1A	Removal of the Housing and the Fixation cover assembly.
 <p>Fixation cover assembly</p> <p>Housing Screw</p> <p>Screw</p>		<ol style="list-style-type: none"> 1. Loosen the screw turning it counterclockwise, using a coin or a flat blade screwdriver. 2. Take out the belt hook. 3. Remove nine housing screws. 4. Open the housing B. 5. Take out the fixation cover, protectors and anvil block.

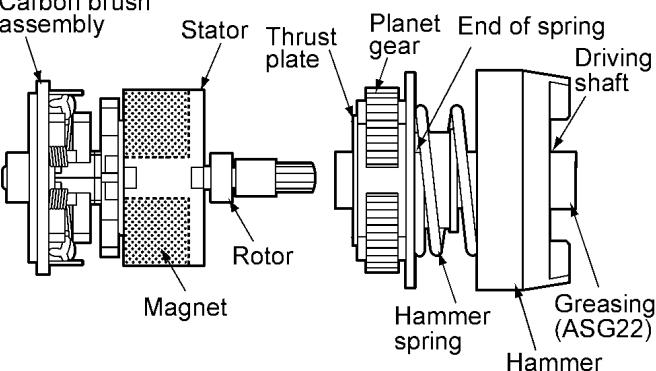
Ref. No. 1B	Procedure 1A → 1B	Removal and attachment of the Motor.
 <p>Carbon brush assembly</p> <p>Stator</p> <p>Thrust plate</p> <p>Planet gear</p> <p>End of spring</p> <p>Driving shaft</p> <p>Rotor</p> <p>Magnet</p> <p>Hammer spring</p> <p>Greasing (ASG22)</p> <p>Hammer</p>		<p>(Removal)</p> <ol style="list-style-type: none"> 1. Take out the motor with the driving block from housing. 2. Separate the motor assembly from the driving block. 3. Take out the motor rotor assembly from the motor stator. <p>NOTE : Make sure not to damage the magnet by motor rotor.</p> <p>(Attachment)</p> <ol style="list-style-type: none"> 1. Insert the motor rotor assembly into the stator. <p>NOTE : Make sure that the motor stator has their own direction for proper assembly. If it is assembled wrongly, the rotation may be the opposite way.</p>

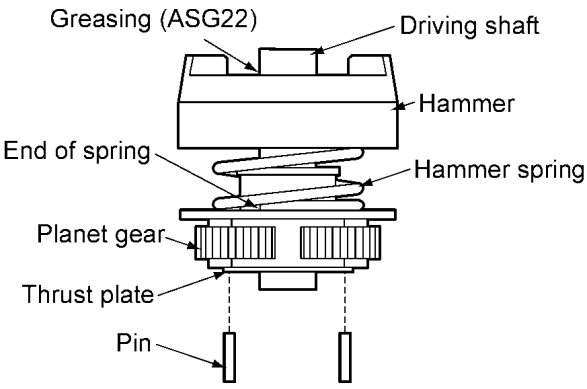
Ref. No. 1C	Procedure 1A → 1B → 1C	Removal of the Driving Block.
		<ol style="list-style-type: none"> 1. Remove the thrust plate. 2. Take out the planet gears and pins slightly tapping the driving block on the table.

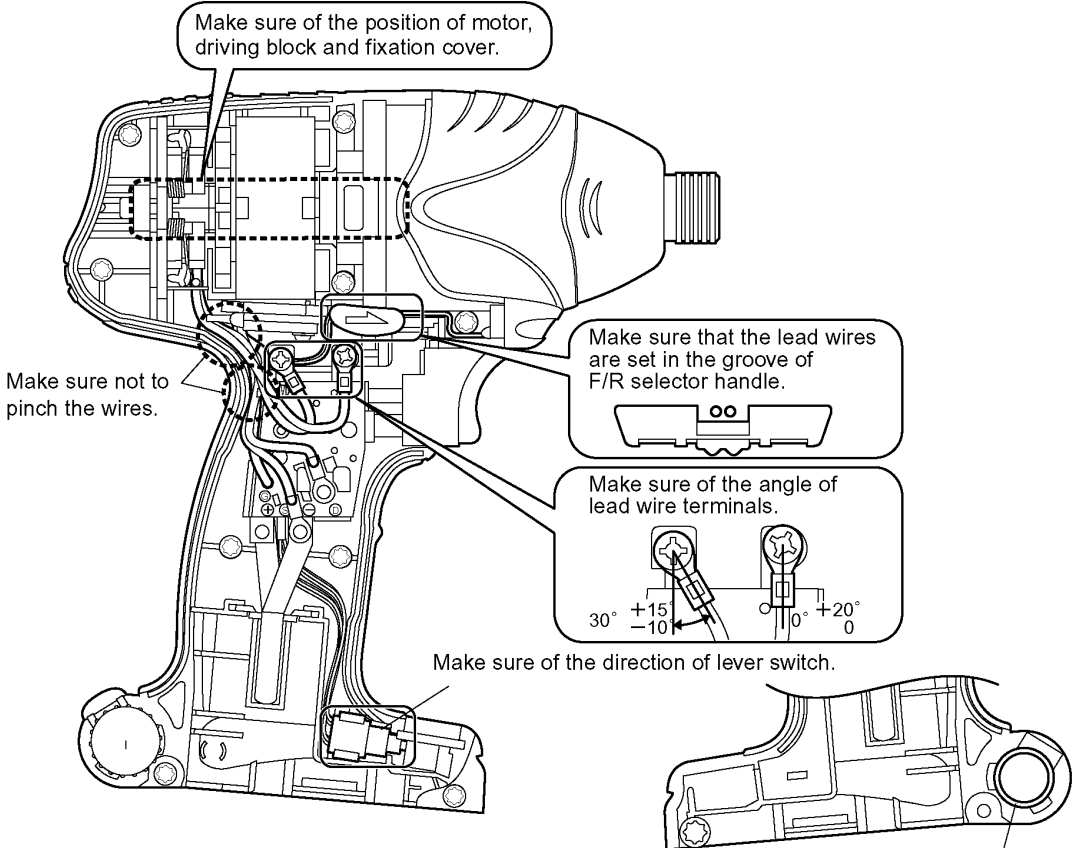
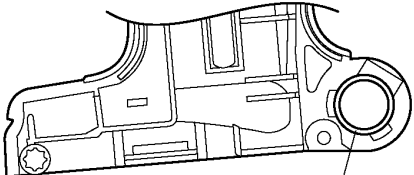
Ref. No. 1D	Procedure 1A → 1B → 1C → 1D	Assembly of the Switch.
		<ol style="list-style-type: none"> 1. Press fit the lead wires firmly. 2. Assembly the lever switch with a projection on top. 3. Connect the motor lead wires without touching (+) terminal and (-) terminal. 4. Press fit the lead wires of LED light in a groove of F/R selector handle.
 <p data-bbox="858 1727 1358 1756">Set the spring by holding the projection of housing.</p>		

4 TROUBLESHOOTING GUIDE

(Refer to WIRING CONNECTION DIAGRAM)

< TROUBLE >

Does not operate.

→

< CHECK >

<CHECK BATTERY PACK.>

If no less than 12V DC is available across the (+) and (-) terminals, the battery pack is OK.

NOTE: The battery pack is sold separately as an optional accessory. See the nearest sales dealer for details. The battery pack has a limited life.
The pack should be replaced if;

- after being charged for the rated charging time the battery voltage is less than 12V DC or the usable time is extremely short.
- the battery leaks. Check battery for leaks and terminals for corrosion.

NO

→

< REMEDY >

Replace battery pack.

↓OK

<CHECK TERMINAL CONNECTIONS BETWEEN MAIN UNIT
AND BATTERY PACK.>

Check for proper terminal contacts.

NO

→

Repair contacts.

↓OK

<CHECK SWITCH BLOCK.>

(See WIRING CONNECTION DIAGRAM.)

Check continuity between following terminals.

* Inspection of the forward / reverse selection switch.

When switch handle is depressed all the way:

- There should be 0Ω between (B) - (D) , when switch lever is set to forward side.
- There should be 0Ω between (A) - (D) , when switch lever is set to reverse side.

NO

→

Contacts in switch block are defective.
Replace switch & FET block.

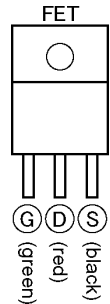

↓OK

<CHECK MOTOR BRUSH.>

- A. Check the condition of carbon brush.
(Do not touch between brush holder and holding spring.)
- B. There should be 0Ω between motor lead wire and terminal of brush holder.

NO

→

Replace motor brush assembly.

↓OK

<CHECK MOTOR ROTOR.>

Check the condition of rotor if there is any wear, crack and deformation.

NO

→

Replace motor rotor assembly.

↓OK

<CHECK MOTOR STATOR.>

Check the condition of motor case if there is any crack and deformation.

NO

→

Replace motor stator.

< TROUBLE >	< CHECK >	< REMEDY >
Does not speed-control.	<p align="center"><CHECK FET.></p> <p>Even if FET block is defective, it can not be replaced individually. Replace whole switch block. Remove the FET circuit block and check the lead wire terminals. These terminals are open normally when there is an open circuit ($\infty \Omega$) between the green and red lead wires, and between the black and red lead wires.</p> <p>NOTE:</p> <ul style="list-style-type: none"> * FET is weak against static electricity. ** The resistance value may be some differences depends on the measurement range. 	NO → Repair the contact or replace switch & FET block.

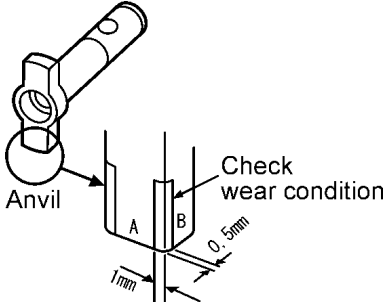
< TROUBLE >	< CHECK >	< REMEDY >
Does not vibrate or weakness of vibration.	<p align="center"><CHECK ANVIL.></p> <p>Check wear condition of anvil. If no less than 1mm from the corner at (A) side or 0.5mm from the corner at (B) side, anvil is OK.</p>  <p>The diagram shows a side view of an anvil being struck by a hammer. Two points, A and B, are marked on the anvil's face. Point A is at the top corner, and point B is at the bottom corner. Dimension lines indicate that the distance from the corner at point A must be at least 1mm, and the distance from the corner at point B must be at least 0.5mm. The text 'Check wear condition' is written near point B.</p>	NO → Replace anvil.

↓OK

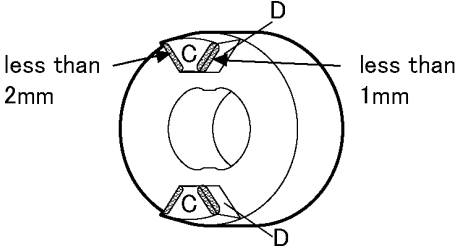
< CHECK >	< REMEDY >
<p align="center"><CHECK HAMMER.></p> <p>Check wear condition of hammer. If no less than 2mm from the corner at (C) side or 1mm from the corner at (D) side, hammer is OK.</p>  <p>The diagram shows a top-down view of a hammer head. Two points, C and D, are marked on the hammer's face. Point C is at the top corner, and point D is at the bottom corner. Dimension lines indicate that the distance from the corner at point C must be at least 2mm, and the distance from the corner at point D must be at least 1mm.</p>	NO → Replace hammer.

5 EXPLODED VIEW

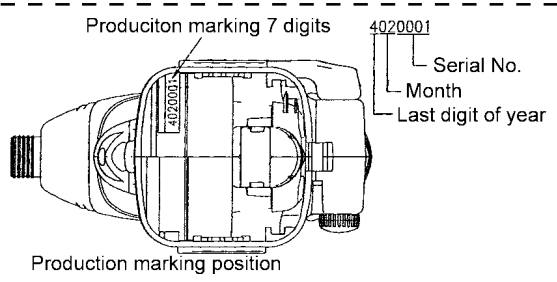
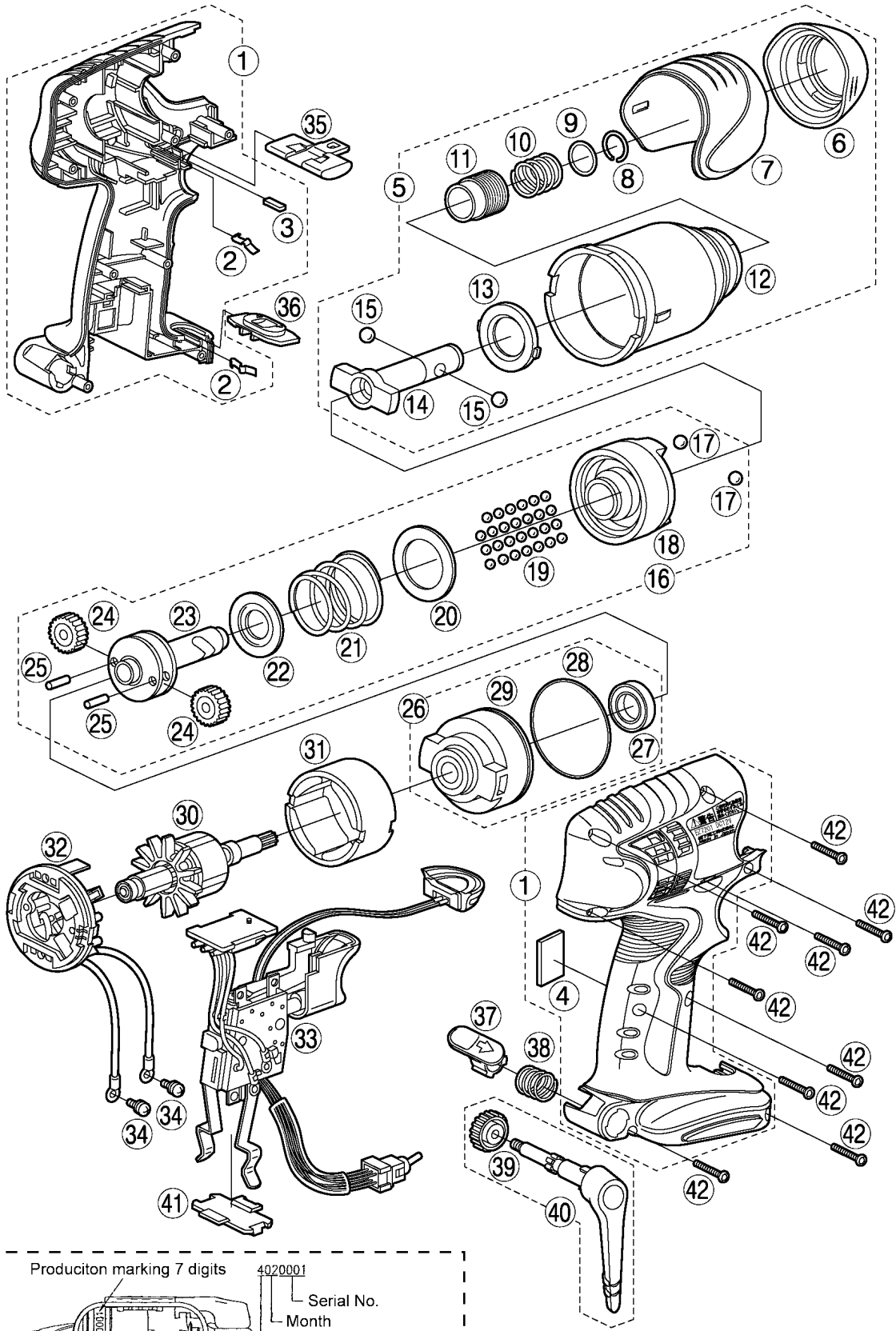

6 REPLACEMENT PARTS LIST

NOTE:

*B=only available as set

*C=available individually

Ref.No.	Part No.	Part Name & Description	Remarks		Per Unit
1	WEY7201K3079	HOUSING AB SET		for EUROPE	1
1	WEY7201K3070	HOUSING AB SET		for OCEANIA	1
2	WEY6481L0177	CLICK SPRING	*C		2
3	WEY7201L0317	CUSHION	*B	(2PCS/PK) 4*10*2	2
4	WEY7201L0327	CUSHION		4.0*23*33	1
5	WEY7201H4057	FIXATION COVER ASSEMBLY			1
6	WEY7201K3107	NOSE PROTECTOR			1
7	WEY7201H3207	PROTECTOR			1
8	WEY6507K1167	C-TYPE RING			1
9	WEY6507L0857	THRUST PLATE			1
10	WEY6507L0197	BIT HOLDER SPRING			1
11	WEY6507K3717	BIT HOLDER			1
12	WEY7201S3307	FIXATION COVER			1
13	WEY6505L0867	SLIDER			1
14	WEY7201L1127	ANVIL			1
15	WEY6507L6977	STEEL BALL	*B	(2PCS/PK) \varnothing 5/32	2
16	WEY7201L1067	DRIVING SHAFT ASSEMBLY			1
17	WEY7201L6967	STEEL BALL	*B	(2PCS/PK) \varnothing 7/32	2
18	WEY7201L1377	HAMMER			1
19	WEY7300L6957	STEEL BALL	*B	(27PCS/PK)	27
20	WEY6505L0897	THRUST PLATE			1
21	WEY7201L0157	HAMMER SPRING			1
22	WEY6508L1147	SPRING FIXING PLATE			1
23	WEY7201L1137	DRIVING SHAFT			1
24	WEY6506L1357	PLANET GEAR	*B	(2PCS/PK)	2
25	WEY6506L1347	PIN	*B	(2PCS/PK)	2
26	WEY7201L0027	MOTOR MOUNTING PLATE ASSEMBLY			1
27	WEY7201L4957	BEARING			1
28	WEY7201L0987	O-RING		\varnothing 41	1
29	WEY7201L3747	MOTOR MOUNTING PLATE			1
30	WEY7201L1467	MOTOR ROTOR ASSEMBLY			1
31	WEY7201L1187	STATOR			1
32	WEY7201L2307	BRUSH ASSEMBLY			1
33	WEY7201K2007	SWITCH			1
34	WEY6261B6027	SEMS SCREW	*C	K3-6	2
35	WEY7201Y3247	F/R SELECTOR HANDLE			1
36	WEY7201Y3257	IMPACT MODE SELECTOR SWITCH			1
37	WEY7201Y3267	BELT HOOK LOCK LEVER			1
38	WEY7201L0167	SPRING			1
39	WEY6470K3187	BELT HOOK BOLT			1
40	WEY7201Y3317	BELT HOOK			1
41	WEY6230L0207	DUST PREVENTIVE PLATE			▲
42	WEY6230K9218	TORX TAPPING SCREW	*C	K3*20	▲
-	WEY9597K7018	TOOL CASE			▲
-	WEY7201K8109	OPERATING INSTRUCTIONS			▲

**Battery Pack is available as an optional accessory. See the nearest sales dealer for details.

***For replacement parts of charger, see the charger service manual.

Charger complete set is available as an optional accessory. See the nearest sales dealer for details.